

---

## Evaluating Accessibility for Transportation Planning

*Measuring People's Ability To Reach Desired Goods and Activities*

15 April 2011

Todd Litman

*Victoria Transport Policy Institute*



*The Brooklyn Bridge provides access between Manhattan and Brooklyn.*

### **Abstract**

This paper discusses the concept of *accessibility* and how it can be incorporated in transport planning. Accessibility refers to people's ability to reach goods, services and activities, which is the ultimate goal of most transport activity. Many factors affect accessibility, including mobility (physical movement), the quality and affordability of transport options, transport system connectivity, mobility substitutes, and land use patterns. Accessibility can be evaluated from various perspectives, including a particular group, mode, location or activity. Conventional planning tends to overlook and undervalue some of these factors and perspectives. More comprehensive analysis of accessibility in planning expands the scope of potential solutions to transport problems.

A shorter version of this paper was presented at the  
87<sup>th</sup> Transportation Research Board Annual Meeting ([www.trb.org](http://www.trb.org)), January 2008.

Todd Alexander Litman © 2007-2011

You are welcome and encouraged to copy, distribute, share and excerpt this document and its ideas, provided the author is given attribution. Please send your corrections, comments and suggestions for improvement.

## Contents

<b>Introduction .....</b>	<b>2</b>
<b>Defining Accessibility.....</b>	<b>3</b>
<b>Factors That Affect Accessibility .....</b>	<b>5</b>
Transportation Demand and Activity .....	5
Mobility .....	6
Transportation Options.....	7
User Information.....	9
Integration, Terminals and Parking .....	10
Affordability.....	11
Mobility Substitutes .....	12
Land Use Factors .....	13
Transportation Network Connectivity .....	17
Roadway Design and Management .....	19
Prioritization.....	20
The Value of Inaccessibility.....	22
Summary of Factors Affecting Accessibility .....	23
<b>Perspectives .....</b>	<b>24</b>
Individuals and Groups .....	24
Mode .....	25
Location.....	25
Activity .....	26
Summary .....	26
<b>Evaluating Accessibility .....</b>	<b>27</b>
<b>Optimal Accessibility and Mobility.....</b>	<b>33</b>
<b>Evaluating Automobile Dependency.....</b>	<b>34</b>
<b>Strategies for Improving Accessibility.....</b>	<b>36</b>
<b>Best Practices .....</b>	<b>39</b>
<b>Conclusions.....</b>	<b>42</b>
<b>References And Resources For More Information .....</b>	<b>43</b>
<b>Acknowledgements .....</b>	<b>48</b>

An automobile is a machine for mobility. A city is a machine for accessibility.

When people say, “location, location, location,” they really mean “accessibility, accessibility, accessibility.”

## Introduction

A *paradigm shift* (a fundamental change in how problems are defined and solutions evaluated) is occurring in transportation planning. This can be described as a shift from *mobility-oriented analysis* (which evaluates transport system performance based on quantity and quality of physical travel) to *accessibility-based analysis* (which considers a broader range of impacts and options). As with the Copernican revolution, this paradigm shift changes what we assume to be the center. Conventional, mobility-based planning places *automobiles* at the center of the transport system. The new, accessibility-based paradigm places *people* at the center.

This shift has important implications for transport planning. It changes the definition of transport problems and how potential solutions are evaluated. Mobility-based planning tends to evaluate transport system performance based largely on traffic speeds and so favors automobile-oriented transport improvement. Accessibility-based planning considers other impacts and options, including improvements to alternative modes, incentives to change travel behavior, and more accessible land use (VTPI 2006).

Many current planning practices tend to favor mobility over accessibility and automobile travel over alternative modes (Cambridge Systematics 2010; Litman 2007). For example:

- Transport system performance is often evaluated based on travel *speed* and *distance*, which favors faster modes and quantitative improvements over slower modes and qualitative improvements (such as increased passenger convenience and comfort).
- Travel statistics often undercount and undervalue nonmotorized travel by ignoring short trips, children's travel, non-commute trips, and non-motorized links of motorized trips.
- The benefits from increased vehicle traffic volumes and speeds are recognized, but reductions in walkability and land use accessibility are often overlooked.

Such planning practices can result in decisions that increase mobility but reduce overall accessibility (for example, by reducing travel options and stimulating sprawl), and tend to undervalue other accessibility improvement options (such as more accessible land use development, and mobility substitutes such as telework). More comprehensive analysis can help decision-makers identify more optimal solutions.

There is no single way to evaluate accessibility. Different planning issues require different methods to account for different users, modes, scales and perspectives. For example, neighborhood planning requires more walkability analysis, while regional planning requires more analysis of automobile, bus and rail travel. Evaluating access for lower-income populations differs from that of wealthier and business travelers.

This paper provides guidance for applying various types of accessibility analysis in transport planning. It defines the concept of accessibility, describes factors that affect people's ability to reach destinations and perspectives to consider, discusses evaluation methods, and describes options for improving access. This document should be useful to transport planners, modelers and decision-makers.

## Defining Accessibility

*Accessibility* (or just *access*) refers to the ease of reaching goods, services, activities and destinations, which together are called *opportunities*. It can be defined as the potential for *interaction* and *exchange* (Hansen 1959; Engwicht 1993). For example, grocery stores provide access to food. Libraries and the Internet provide access to information. Paths, roads and airports provide access to destinations and therefore activities (also called *opportunities*). Accessibility can be defined in terms of *potential* (opportunities that could be reached) or in terms of *activity* (opportunities that are reached). Even people who don't currently use a particular form of access may value having it available for possible future use, called *option value*. For example, motorists may value having public transit services available in case they are unable to drive in the future.

Access is the goal of most transport activity, except the small portion of travel for which mobility is an end in itself (e.g., jogging, cruising, leisure train rides). Even recreational travel usually has a destination, such as a resort or campsite. Various disciplines analyze accessibility, but their perspective is often limited:

- Transport planners generally focus on mobility, particularly vehicle travel.
- Land use planners generally focus on geographic accessibility (distances between activities).
- Communications experts focus on telecommunication quality (such as the portion of households with access to telephone, cable and Internet services).
- Social service planners focus on accessibility options for specific groups to specific services (such as disabled people's ability to reach medical clinics and recreation centers).

### Other Meanings

The words *accessibility* and *access* can have various meanings and implications.

- *Accessibility* generally refers to *physical access* to goods, services and destinations, which is what people usually mean by *transportation*.
- In roadway engineering, *access* refers to connections to adjacent properties. *Limited access* roads have minimal connections to adjacent properties, while local roads provide direct access. *Access management* involves controlling the number of intersections and driveways on a highway.
- In the fields of geography and urban economics, *accessibility* refers to the relative ease of reaching a particular location or area.
- In pedestrian planning and facility design *accessible design* (also called *universal design*) refers to facilities designed to accommodate people with disabilities. For example, a pathway designed to accommodate people in wheelchairs may be called *accessible*.
- In social planning, *accessibility* refers to people's ability to use services and opportunities.

How transportation is evaluated affects planning decisions. For example, if transportation is evaluated based on *vehicle travel conditions* (traffic speeds, congestion delay, roadway Level-of-Service ratings), the only way to improve transport system quality is to improve roadways. If transportation is evaluated based on *mobility* (movement of people and

goods), then rideshare and public transit service improvements can also be considered. If transportation is evaluated based on *accessibility* (people’s overall ability to reach desired goods, services and activities), additional transportation improvement options can be considered (besides roadway, rideshare and public transit), including improved walking and cycling conditions, more accessible land use patterns to reduce travel distances, and telecommunications and delivery services that substitute for physical travel. Table 1 compares these perspectives.

**Table 1 Transportation Evaluation Perspectives (Litman 2003)**

	Vehicle Travel	Mobility	Accessibility
Definition of <i>Transportation</i>	Vehicle travel	Person and goods movement	Ability to obtain goods, services and activities
Measurement units	Vehicle miles	Person-miles and ton-miles	Trips, generalized costs
Modes considered	Automobile and truck	Automobile, truck and transit	Automobile, truck, transit, cycling and walking
Common indicators	Vehicle traffic volumes and speeds, roadway Level of Service, costs per vehicle-mile, parking convenience	Travel distance and speeds, road and transit Level of Service, cost per person-mile, travel convenience	Quality of available transportation choices. Distribution of destinations. Cost per trip
Consumer benefits considered	Maximum motor vehicle travel and speed	Maximum personal travel and goods movement	Maximum transport choice and cost efficiency
Consideration of land use	Treats land use as an input, unaffected by transportation decisions	Recognizes that land use can affect travel choice	Recognizes that land use has major impacts on transportation
Favored transportation improvement strategies	Roadway and parking facility improvements to increase capacity, speed and safety	Transportation system improvements that increase capacity, speeds and safety	Management strategies and improvements that increase transport system efficiency and safety
Transportation Demand Management (TDM)	Generally considers vehicle travel reductions undesirable	Supports TDM strategies that improve personal and freight mobility	Supports TDM whenever it is cost effective

*This table compares three common perspectives used to measure transportation.*

Accessibility-based analysis therefore expands the range of possible solutions to transport problems, which can lead to better solutions. For example, if a school experiences traffic or parking congestion problems, vehicle-travel-based analysis would conclude that roads and parking facilities must be expanded. Mobility-based analysis would conclude that roads and parking facilities could be expanded, or that students could travel by bus, rather than drive alone. Accessibility-based analysis would compare those solutions with others, such as locating more schools in neighborhoods where the distance that children must travel to school is short enough to allow more walking and cycling. This solution offers many additional benefits, including infrastructure cost savings (reduced road and parking requirements), user cost savings (parents no longer need to drive), reduced pollution emissions, and increased fitness and health.

## Factors That Affect Accessibility

*This section describes specific factors that affect accessibility and how they should be evaluated.*

### **Transportation Demand and Activity**

*Transportation demand* refers to the amount of mobility and accessibility people would consume under various conditions. *Transportation activity* refers to the amount of mobility and accessibility people actually experience. People typically make 1-3 daily trips outside their home, with higher levels of demand for people who commute to school or jobs, care for dependents (such as children or disabled adults), and have higher incomes (ITE 2003). Travel demand can be categorized in various ways:

- *Demographics* (age, income, employment status, gender, etc.)
- *Purpose* (commuting, personal errands, recreation, etc.).
- *Destination* (school, job, stores, restaurants, parks, friends, families, etc.). These can be divided into *common* destinations (goods and services available at many locations) and *unique* destinations (activities at a particular destination, such as a friend's house).
- *Time* (hour, day, season).
- *Mode* (walking, cycling, automobile driver, automobile passenger, transit passenger, etc.). *Mode split* (the portion of trips made by different modes) is affected by factors such as vehicle availability, the quality of alternative modes and community design.
- *Distance* (from origin to destination, and from origin to access each mode, such as walking distance to transit stations).

Travel demand is often treated as a fixed value. For example a planner might say, "Vehicle traffic demand will increase 20% in ten years." But factors such as price and service quality affect demand, so planners should indicate how policies affect it, for example, by saying "Vehicle traffic is projected to increase by 20% over the next decade if current policies continue, 10% with moderate mobility management, and 0% with aggressive mobility management." This lets communities to determine their mobility.

Most people consider a certain amount of mobility desirable (Mokhtarian and Salomon 2001; Colonna 2009), including walking, cycling, driving and public transit (Handy, 1993). People enjoy certain travel activities, such as drives in the countryside, holiday trips. Even utilitarian trips, such as errands and commuting, may be longer than necessary due to travel enjoyment. However, travel time research indicates that most people would prefer to devote less time to travel ("Travel Time Costs," Litman 2006a).

### *Implications:*

- Demographic and geographic factors affect demand for mobility and access. Attending school, being employed, or having dependents increases demand.
- Price, quality and other factors affect demand for each mode and therefore mode split.
- As accessibility improves people tend to access more opportunities.
- People enjoy a certain amount of travel.

### **Mobility**

*Mobility* refers to physical movement, measured by trips, distance and speed, such as person-miles or –kilometers for personal travel, and ton-miles or tonne-kilometers for freight travel. All else being equal, increased mobility increases accessibility: the more and faster people can travel the more destinations they can reach.

Conventional planning tends to evaluate transport system quality primarily based on mobility, using indicators such as average traffic speed and congestion delay (Litman 2001). Congestion often constrains urban-peak vehicle travel, limiting accessibility. However, efforts to increase automobile traffic speeds and volumes can reduce other forms of accessibility, by constraining pedestrian travel and stimulating more dispersed, automobile-oriented development patterns. Improving high occupant vehicle (HOV) travel and favor it over driving can reduce congestion increase personal mobility (person-miles of travel) without increasing vehicle mobility (vehicle-miles of travel).

Different modes have different speeds and different scales of accessibility (Krizek, et al. 2007). For example, in 5 minutes a typical pedestrian can walk about a ½ mile and so can access 36 square blocks, while a cyclist can travel about one mile and access 256 square blocks, and a motorist can travel 2 miles and access 2,500 square blocks.

**Figure 1** Accessible by Different Modes

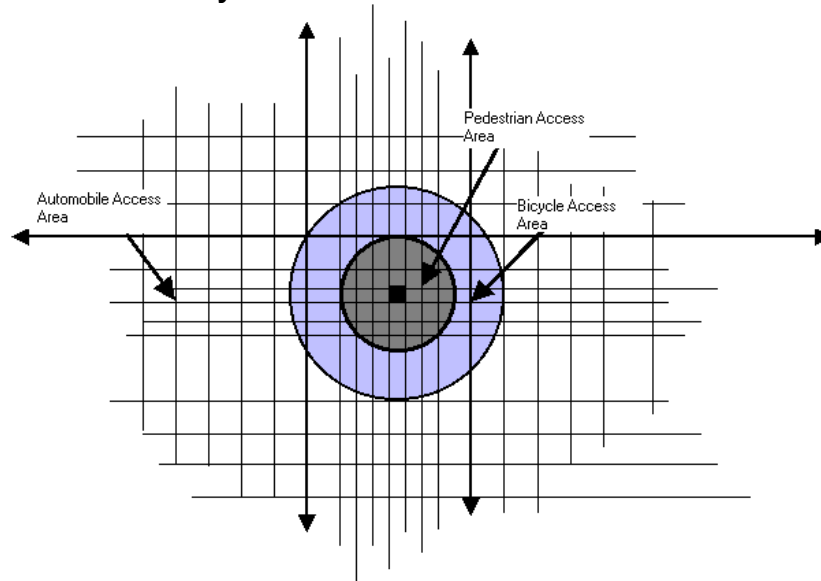

*Increased speed can result in a proportionally larger increase in accessible area.*

#### *Implications:*

- More and faster travel increases accessibility.
- Congestion can limit accessibility by a particular mode.
- Efforts to increase automobility can reduce other forms of accessibility.

- Higher occupancy modes can increase personal mobility without increasing vehicle travel.

**Transportation Options**

*Transportation options* (also called *mobility options*, *transport diversity* and *transport choice*) refer to the quantity and quality of transport modes and services available in a particular situation. In general, improving transport options improves accessibility. Different modes serve different users and purposes, as summarized in Table 2.

**Table 2 Suitability of Transport Modes**

Mode	Non-Drivers	Poor	Handi-capped	Limitations	Most Appropriate Uses
Walking	Yes	Yes	Varies	Requires physical ability. Limited distance and carrying capacity. Difficult or unsafe in some areas.	Short trips by physically able people.
Wheelchair	Yes	Yes	Yes	Requires sidewalk or path. Limited distance and carrying capacity.	Short urban trips by people with physical disabilities.
Bicycle	Yes	Yes	Varies	Requires bicycle and physical ability. Limited distance and carrying capacity.	Short to medium length trips by physically able people on suitable routes.
Taxi	Yes	Limited	Yes	Relatively high cost per mile.	Infrequent trips, short and medium distance trips.
Fixed Route Transit	Yes	Yes	Yes	Destinations and times limited.	Short to medium distance trips along busy corridors.
Paratransit	Yes	Yes	Yes	High cost and limited service.	Travel for disabled people.
Auto driver	No	Limited	Varies	Requires driving ability and automobile. High fixed costs.	Travel by people who can drive and afford an automobile.
Ridesharing (auto passenger)	Yes	Yes	Yes	Requires cooperative motorist.	Trips in which motorists can carry additional passengers.
Carsharing (Vehicle Rentals)	No	Limited	Varies	Requires convenient and affordable vehicle rentals services.	Occasional use by drivers who don't own an automobile.
Motorcycle	No	Limited	No	Requires riding ability and motorcycle. High fixed costs.	Travel by people who can ride and afford a motorcycle.
Telecommute	Yes	Varies	Varies	Requires equipment and skill.	Alternative to some types of trips.

*Each mode is suitable for certain purposes.*

Conventional evaluation tends to evaluate accessibility based primarily on travel speeds (such as average traffic speeds and congestion delay), but convenience and comfort factors are also important (Litman 2007a). *Level-of-service* (LOS) ratings, which grade service quality from A (best) to F (worst), can be used to evaluate travel conditions, for example, to identify problems and possible improvements. Table 3 summarizes level-of-service rating factors for various modes.

Special models are sometimes used to quantify accessibility by a particular mode. For example, Minocha, et al. (2008) evaluate transit employment accessibility using an index of transit service quality (frequency and station quality) and transit travel times to employment areas.



**Table 3 Multi-Modal Level Of Service** (“Transport Options,” VTPI 2006; FDOT 2007)

Mode	Level of Service Factors
Universal design (disability access)	Degree to which transport facilities and services accommodate people with disabilities and other special needs.
Walking	Sidewalk/path quality, street crossing conditions, land use conditions, security, prestige.
Cycling	Path quality, street riding conditions, parking conditions, security.
Ridesharing	Ridematching services, chances of finding rideshare matches, HOV priority.
Public transit	Service coverage, frequency, speed (particularly compared with driving), vehicle and waiting area comfort, user information, price, security, prestige.
Automobile	Speed, congestion delay, roadway conditions, parking convenience, safety.
Telework	Employer acceptance/support of telecommuting, Internet access.
Delivery services	Coverage, speed, convenience, affordability.

*This table indicates specific factors for evaluating the service quality of various transport modes.*

Leigh, Scott & Cleary (1999) developed a method for quantifying a community’s *mobility gap*, defined as the amount of additional transit service required for vehicle lacking-households to enjoy mobility levels comparable to vehicle-owning households. This is a conservative estimate because it does not account for unmet mobility needs of non-drivers in vehicle-owning households. Only about a third of transit needs are currently being met in the typical areas they evaluated, indicating a level of service (LOS) rating D, based on ratings shown in Table 4. The approach can be used to predict the LOS rating that will occur under various transit planning and investment scenarios.

**Table 4 Transit Level Of Service Ratings** (Leigh, Scott & Cleary 1999, p. VIII-3)

Portion Demand Met	Transit Level-Of-Service	Portion Demand Met	Transit Level-Of-Service
90% or more	A	25-49%	D
85-89%	B	10-24%	E
50-74%	C	Less than 10%	F

Sometime, a particular factor significantly affects accessibility. For example, inadequate information or poor security around transit stations can constrain transit use (potential riders don’t know how to use it or have exaggerated fears of discomfort and risk).

*Implications:*

- Improving transport options tends to improve accessibility. Improvements can include increased convenience, speed, comfort, affordability, security, user information and prestige.
- Destinations served by more modes or better quality service tend to have better access.
- Evaluating accessibility requires detailed understanding of people’s access needs and abilities, travel mode constraints, and the quality of service at a destination.

### ***User Information***

The quality of information can affect the functional availability and desirability of mobility and accessibility options. For example, motorists need accurate and convenient information on travel routes, roadway conditions (such as when congestion, construction and accidents delay traffic), vehicle services, and the availability and price of parking. Potential transit users need information on transit routes, schedules, fares, comfort factors (such as whether vehicles will have seats or stations will have washrooms), and access to destinations. Walkers and cyclists need information on recommended routes, and cyclists need information on parking options. Information on destinations (such as whether a store offering a particular good is within convenient walking distance) can also affect accessibility.

There are many ways to provide transportation information, including maps, brochures, websites and telephones systems. New communications systems can significantly improve transportation user information, including in-vehicle navigation systems for motorists, websites with detailed transit route and schedule information, real-time information on transit vehicle location and arrival (websites accessible by mobile telephone, and monitors at transit stops, can indicate the number of minutes until a particular bus or train will arrive at a particular location), and various scale maps and guides for pedestrians and cyclists. The effectiveness of such information depends on how well potential users are aware of, can access, and actually apply this information.

#### *Implications:*

- The availability and accuracy of user information affects accessibility.
- In many situations, improving user information is a cost effective way of improving accessibility.
- The effectiveness of such information depends on how well potential users are aware of, can access, and actually apply information.

### ***Integration, Terminals and Parking***

Accessibility is affected by the quality of system integration, such as the ease of transferring between modes, the quality of stations and terminals, and parking convenience.

Automobile transportation is generally well integrated. Most destinations have abundant and generally free or low-priced parking, and most transfer stations (airports, train and bus stations, ferry terminals and ports) are located and designed for convenient highway access, vehicle parking and often vehicle rental services. Motorists generally have good information through signs and maps.

The integration of other modes varies significantly, and inadequate integration is sometimes a major barrier to non-automobile accessibility. For example, airports and ferry terminals are sometimes difficult to access by public transit, and bus stops and train stations are sometimes uncomfortable and difficult to access, particularly by people with disabilities, children, and people carrying heavy loads. Some destinations lack suitable bicycle parking and changing facilities. It is often difficult to obtain accurate information on alternative modes.

#### *Implications:*

- The connections between links and modes affect accessibility.
- The location and quality of transportation terminals affects the accessibility of the modes they serve. The quality of bus stops, train stations, ferry terminals and other transfer facilities affects the relative accessibility of these modes.
- The availability, price and convenience of parking affect automobile accessibility.
- Bicycle transportation is facilitated by appropriate bicycle parking and storage facilities (including some covered and secure parking), and changing facilities at worksites.

### **Affordability**

*Transportation Affordability* means that user financial costs of transport are not excessive, particularly for basic access (travel with high social value). Individual and community factors influence transportation affordability. Motorists are primarily affected by the affordability of driving, while non-drivers are more affected by the affordability of alternative modes, such as public transit and taxi services.

Transportation affordability can be evaluated in several ways, including the quality and costs of using various modes (particularly modes used by people with lower incomes, such as walking, cycling, public transit, used cars, and taxi services), the affordability of living in more accessible locations, and the portion of total household budgets devoted to transport. Requiring lower-income households to spend more than about 20% of their budget on transport can be considered unaffordable. Lower-income workers in automobile-dependent communities tend to bear particularly high transportation costs (“Affordability,” VTPI 2006). Because lower-income households tend to own older, less reliable vehicles, and have high insurance costs, they often face problems associated with unexpected breakdowns and associated expenses, high crash risk, and uninsured driving.

Some recent studies use an *affordability index* of combined household housing and transportation costs (including vehicle ownership and operation, and transit fares) to evaluate the cost burden of different housing locations. Lipman (2006) found that the portion of household budgets devoted to housing and transportation averages 48% overall, but for working families with incomes under \$50,000, the combined burden averages 57%, with lower rates in more central locations and higher rates in more dispersed locations.

Planning generally recognizes certain transportation affordability factors, such as vehicle operating costs (fuel prices, road tolls and parking fees) and transit fares, but tends to overlook other factors, particularly the importance of nonmotorized modes, modal integration (such as delivery services that help people shop by walking, cycling and public transit) and location factors. In particular, current planning practices sometimes restrict development of affordable housing, forcing lower-income people to live in automobile-dependent locations where they bear excessive transportation costs.

#### *Implications:*

- Affordability affects accessibility.
- Affordability is especially a problem for lower-income workers.
- Affordability can be improved by reducing user costs (vehicle purchase costs, fuel prices, transit fares, etc.), by improving more affordable modes (such as walking, cycling and public transit), and by increasing land use accessibility.
- Location affects transport affordability. Lower-income residents in automobile-dependent locations tend to spend an excessive portion of their income on transport.

### ***Mobility Substitutes***

Mobility substitutes include *telework* (telecommunications that substitutes for physical travel) and delivery services that provide access with minimal mobility (“Telework,” VTPI, 2006). Mobility substitutes can provide access for many goods and activities. For example, one way to improve access to information is to provide high-speed Internet service, and arrange convenient and inexpensive delivery of library books directly to homes. Similarly, pharmacies may deliver medicines and other medical goods, rather than requiring customers to travel to a store.

However, there are limits to mobility substitute benefits. Many jobs and employees are unsuitable for telecommuting. Although it may be possible to purchase goods online, it is usually less satisfying than visiting a store where the physical goods can be examined. And an email, no matter how articulate, can never substitute for a friend’s smile and hug, as anybody who ever had a long-distance romance will attest. It turns out that virtual access is often less productive and satisfying than physical access.

Mobility substitutes do not necessarily eliminate vehicle travel; in some situations they stimulate additional mobility by allowing more dispersed development and longer commute trips. For example, when given permission to telecommute two or three days a week, some employees use the opportunity to choose more distant home or employment locations, and telecommuters often make additional vehicle trips to run errands that would otherwise be made during while commuting, or to attend meetings or visit friends.

Mobility substitutes can complement other alternative modes. For example, Internet transit schedules can improve transit service, and delivery services can help people shop by walking, cycling and public transit. Mobility substitutes can be particularly effective at reducing vehicle travel if implemented as part of a comprehensive mobility management program that improves travel options and discourages driving.

Most mobility substitutes enjoy economies of scale. For example, high-speed Internet services and most delivery services require a minimal level of demand in a particular area to be cost effective, and as demand increases the quality of service will increase. This may justify subsidies or other favorable public policies to stimulate demand.

#### *Implications:*

- Mobility substitutes can provide access to certain types of activities (primarily involving information exchange), certain types of goods (suitable for shipping), and certain types of users (people who are comfortable using telecommunications equipment).
- Mobility substitutes do not eliminate the need for other types of access, and by themselves may stimulate motorized travel by supporting more dispersed housing and long-distance commutes.
- Mobility substitutes can complement alternative modes, reducing vehicle travel. For example, delivery services allow people to shop by walking, cycling and public transit.

### Land Use Factors

Various *land use* (also called *geographic, urban form* and *built environment*) factors affect accessibility (Litman 2005), including density, mix, connectivity and walkability. A more accessible land use pattern (called *smart growth*) means that less mobility is needed to reach activities and destinations. A typical household's accessibility can be envisioned as a triangle connecting home, work and services. Travel distances and options among these destinations affect overall accessibility. For example, improving the variety of services (shops, schools, restaurants, parks, etc.) within a neighborhood or worksite, and improving travel options from home to worksite, tends to increase accessibility and reduce transport expenditures.

Let's say you typically visit a dozen destinations each week (e.g., worksite, stores, friends, video rental, bookshop, department store, pharmacy, camera shop). Say these destinations are evenly located along a road with your home at one end, as in Figure 2. The more dispersed your destinations, the more travel is required to reach them. If destinations average a half-mile apart, your travel requirements will be half as far as if they average 1 mile apart. If destinations are very close together (say, averaging one or two blocks apart), you can reach them by walking or transit and walking.

*Implications:*

- Increased density and clustering of activities tends to increase accessibility.
- Shorter travel distances can improve transport options (particularly walking).

**Figure 2** Accessibility From A Location At One End Of A Roadway

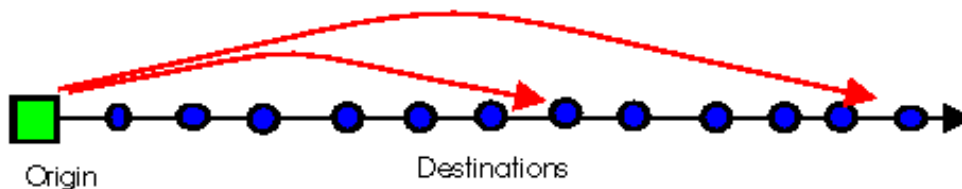

*As destinations are located closer together along a roadway, accessibility increases. If destinations are close enough together, they can be reached by walking.*

Accessibility increases if you are located closer together (Figure 2) and toward the center of a road link (Figure 3), because this reduces the average distance to each destination.

**Figure 3** Accessibility From A Location In The Center Of A Roadway

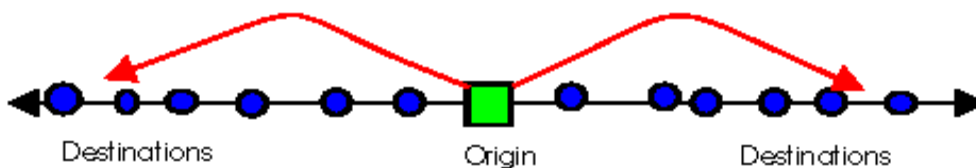

*A more central location reduces travel requirements, increasing accessibility.*

Accessibility can increase if the two ends of a road are connected (a simple form of increased *connectivity*), as in Figure 4, because this may allow you to travel in a loop and avoid backtracking for some types of trips.

**Figure 4** Accessibility From A Location On A Loop Road

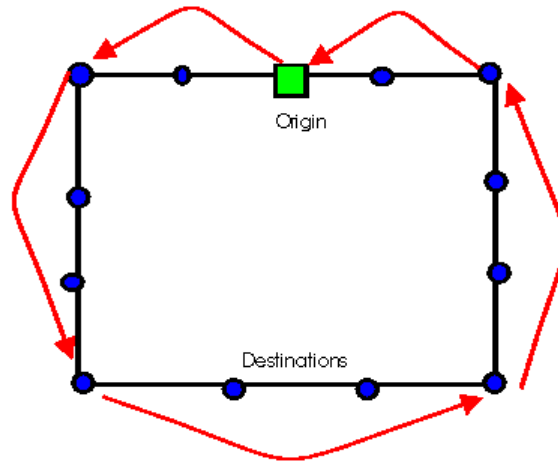

*A connected loop increases route options, increasing accessibility.*

**Figure 5** Accessibility From A Crossroads

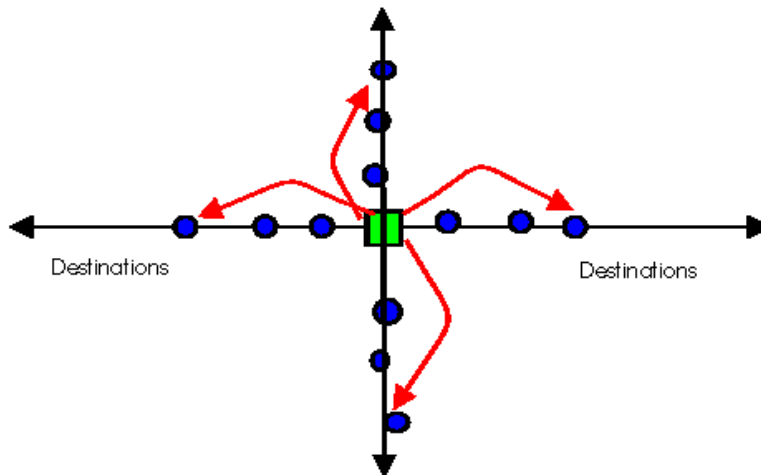

*Locating at a crossroads reduces travel requirements, increasing accessibility.*

Accessibility increases at a crossroads with destinations in each direction, as in Figure 5. Side roads that link destinations, as illustrated in Figure 6, increase accessibility by allowing more direct travel between destinations.

**Figure 6** Accessibility From A Crossroads With Connections

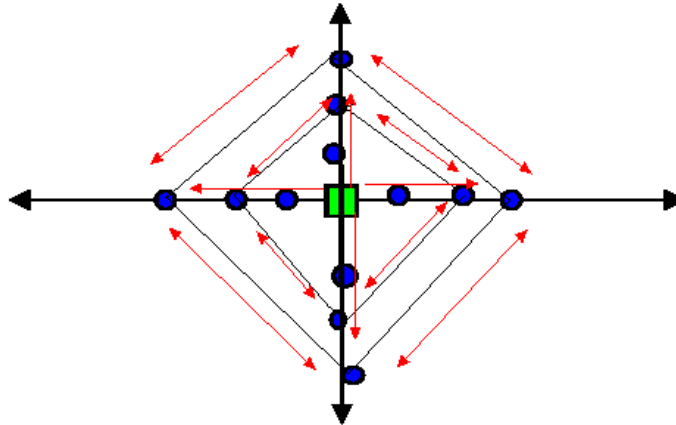

*As the number of roadway connections increases so do route options, increasing accessibility.*

*Implications:*

- A more central location increases accessibility.
- A more connected road network increases accessibility.

*Density* refers to the number of people or jobs per acre. *Clustering* refers to people and activities locating together. Density and clustering are somewhat different concepts. Low-density areas can have a high degree of clustering, such as rural residents and businesses locating in villages. *Land use mix* refers to various types of land use (residential, commercial, institutional, recreational, etc.) located close together. Land use density, clustering and mix tend to increase accessibility (Hine and Grieco 2003). For example, a neighborhood or activity center with housing, stores, offices and transport services located close together provides a high level of accessibility, as illustrated in Figure 7.

**Figure 7** Accessibility With Clustering Of Destinations

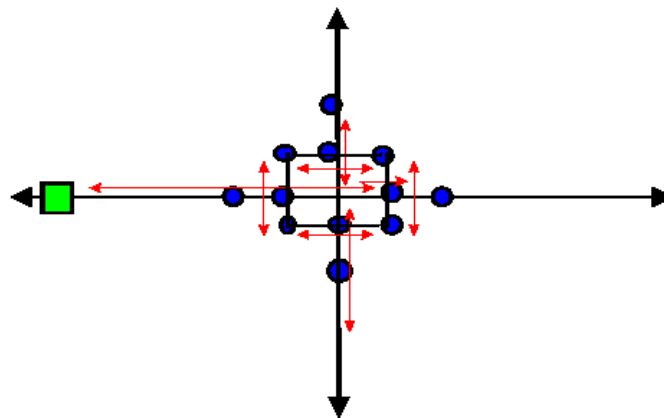

*Clustering increases access to common activities, particularly by walking and public transit.*



Figure 8 illustrates how multi-story buildings can stack destinations on top of each other to achieve greater density and accessibility. Accessibility tends to be greatest on ground floors, because they are directly connected to sidewalks and parking facilities.

**Figure 8** Accessibility With Vertical Clustering

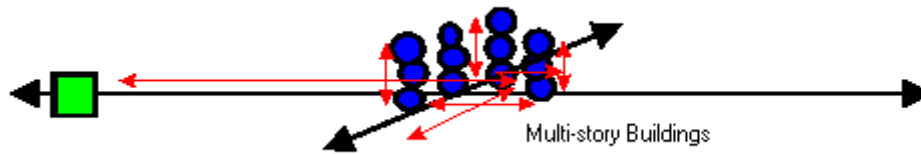

*Vertical clustering (multi-story buildings) can increase accessibility.*

Certain types of activities experience agglomeration economies, that is, they become more efficient and productive if located close together. Many businesses and industries become more productive if located in a commercial center (downtown or mall) close to customers and services. For example, a lawyer becomes more productive if there are plenty of clients nearby, and services such as photocopy shops and accountants are nearby. Similarly, a software industry tend to be more productive if numerous related businesses (programmers, graphic design, digital music, hardware suppliers, specialized law and accounting firms) are located close together.

The relationship between density and accessibility is complex, because increased density and clustering can increase traffic and parking congestion, which reduces automobile accessibility. Other modes, such as walking and public transit, require less space and benefit from density. Clustering activities into a compact center (such as a downtown or mall) makes it feasible to perform numerous errands with one vehicle trip, which is helpful to motorists and even more helpful to transit users.

*Implications:*

- Clustering and mixing of common destinations increases accessibility.
- Generous parking supply tends to improve automobile access but can reduce accessibility by other modes.
- Clustering transportation services into centers and terminals increases accessibility.
- Increasing building height or reducing the amount of land around buildings devoted to parking can increase density and accessibility.
- Certain types of clustering can provide economies of agglomeration.
- Density and clustering may create vehicle traffic and parking congestion, but this may be offset if increased accessibility and transportation diversity reduce vehicle traffic.

### Transportation Network Connectivity

Road and path *connectivity* (also called *permeability*) affect accessibility. Increased connectivity tends to increase accessibility. A grid network (Figure 9), with shorter connected roads, tends provide relatively good accessibility due to multiple routes, more direct connections between destinations, and narrower streets with lower traffic speeds that are better suited to walking and cycling, and therefore to public transit travel (since most transit trips involve walking links).

**Figure 9** Accessibility On Grid Road Network

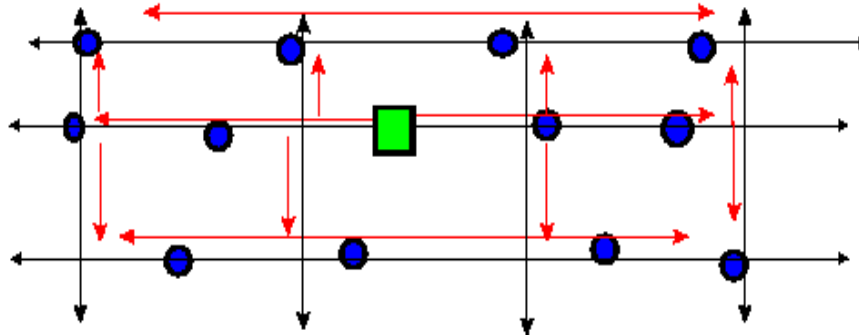

A traditional grid network has many connected roads, providing multiple, direct route choices. This tends to reduce trip distances, increase travel choice, reduce congestion, and increase accessibility.

A *hierarchical* road network (Figure 10), with many dead-end streets connected by wide arterial roads, tends to have higher average traffic speeds but lower overall accessibility due to longer travel distances (since routes are more circuitous), increasing congestion (since traffic is concentrated on arterials), and poor walking and cycling conditions (due to wider roadways and higher speed traffic).

**Figure 10** Accessibility With Hierarchical Road Network

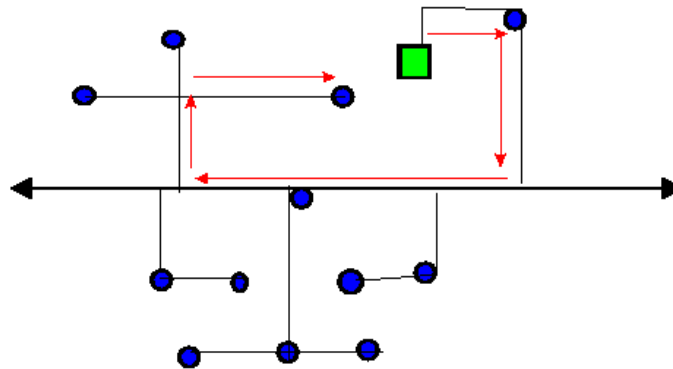

A hierarchical road network channels traffic onto a few major arterials, even for travel between destinations located near to each other. This tends to reduce accessibility, increase congestion and reduce travel options (particularly walking). This roadway design is common in suburban communities.

Cul-de-sac streets are popular because they constrain traffic. An alternative approach is a *modified grid* with connected streets with short blocks and T-intersections to limit traffic speeds, as illustrated in Figure 11. This limits traffic while still allowing more direct routes between destinations. This can be improved further by incorporating paths (dashed lines) that improve access for walking and cycling. Traffic calming can control excessive traffic in older neighborhoods with grid street, as advocated by New Urbanist planners.

**Figure 11** Accessibility On Modified Grid Road And Path Network

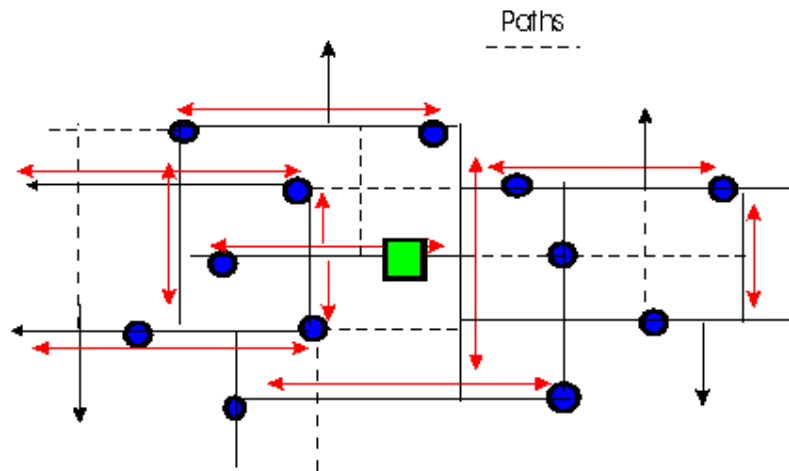

A modified grid has many connected roads designed with short blocks and T-intersections to limit traffic speeds. Paths create shortcuts for walking and cycling. This provides good accessibility, creates a more livable neighborhood and encourages nonmotorized transport.

*Implications:*

- A hierarchical street system with traffic channeled onto major arterials tends to reduce access, increase congestion and degrade nonmotorized travel conditions.
- A grid or modified-grid street system provides more direct access to destinations.
- Pedestrian paths and shortcuts can improve nonmotorized accessibility.

**Connectivity Index**

A *Connectivity Index* evaluates how well a roadway network connects destinations (Ewing, 1996). It is computed by dividing the number of roadway links by the number of roadway nodes. Links are the segments between intersections, and the nodes are the intersections themselves. Cul-de-sac heads count the same as any other link end point. The result can be calculated separately for pedestrian and cycling access, taking into account connections and links for non-motorized travel, such as a path that connects the ends of two cul-de-sacs.

A higher index means that travelers have increased route choice, allowing more direct connections for access between any two locations. According to this index, a simple box is scored a 1.0. A four-square grid scores a 1.33 while a nine-square scores a 1.5. Deadend and cul-de-sac streets reduce the index value. This sort of connectivity is particularly important for nonmotorized accessibility. A score of 1.4 is the minimum needed for a walkable community.

### ***Roadway Design and Management***

Various roadway design and management factors can affect mobility and accessibility. Roadway design decisions often involve tradeoffs between different forms of access. For example, roadway planners must often choose between allocating road space to general traffic lanes, bus lanes, bike lanes, parking lanes, sidewalks, utilities (such as telephone poles), street furniture, and other activities (such as landscaping and sidewalk cafes). Wider and straighter roads with minimum intersections and driveways tend to favor automobile travel, but may be difficult and unpleasant for walking and cycling, and therefore for public transit access. Conversely, design and management strategies, such as expanding pedestrian and cycling facilities, traffic calming, and traffic speed reductions, tend to benefit walking and cycling access, but reduce motor vehicle traffic speeds and capacity, reducing mobility.

#### *Implications:*

- Roadway design and management often involves tradeoffs between different forms of mobility and access.
- Roadway design and management can favor certain modes, users or locations.

### **Prioritization**

*Prioritization* increases transport system efficiency by giving priority to higher value trips and more efficient modes:

- Pricing, which allows higher value travel to outbid lower value travel, based on consumers' willingness-to-pay. For example, road pricing allows higher value vehicle trips to out-bid lower value trips on congested roads, and parking pricing allows motorists access to more convenient parking spaces if they are willing to pay.
- Policies that favor *basic mobility* and *basic accessibility* (transport considered high value by society), such as priority for emergency and freight vehicles in traffic, transit subsidies and special mobility services that provides mobility for people who are transportation disadvantaged, travel to school and work, and universal design (facility and services designed to accommodate all types of users, including people with disabilities).
- High Occupant Vehicle (HOV) priority systems, which give more space-efficient vehicles, such as vanpools and buses, priority over space inefficient vehicles in traffic.
- Location-efficient planning, which encourages major traffic generators (such as employment centers, public services, and large residential buildings) to choose more accessible locations (such as near transit centers and highway intersections, and closer to major cities, as opposed to dispersed, automobile-dependent locations).
- Transportation planning practices that reflect economic efficiency principles, such as *least-cost planning* (funds are allocated to the transportation improvement options that are most cost effective overall, including alternative modes and demand management strategies), and *congestion pricing* (pricing designed to ration road space).

Prioritization increases the value of accessibility provided by a given amount of mobility and a given expenditure on facilities and services. For example, road and parking pricing allow vehicles making higher value trips to outbid lower value trips, and HOV priority strategies allow space efficient modes, such as vanpools and buses, to avoid congestion delays experienced by space inefficient modes. Without prioritization, large investments in roadway capacity expansion may provide virtually no reduction in traffic congestion (due to generated traffic), little net benefits to consumers (since much of the value is captured as a windfall to urban fringe land owners, who see their property values increase), and even negative net benefit to society as the increased vehicle travel increases external costs such as downstream congestion, accidents, pollution emissions and sprawl. Prioritization strategies such as congestion pricing and HOV lanes can improve accessibility while reducing total vehicle travel. Similarly, location-efficient land use development can increase overall accessibility while reducing mobility.

Various terms are currently used for transportation prioritization, including *traffic management* (which refers to strategies that improve traffic flow, such as ramp metering, reversible lanes and HOV priority), *transportation demand management (TDM)* and *mobility management*, which include various strategies that improve travel options, encourage use of efficient modes, and increase land use accessibility, as listed in Table 5. Because these strategies are intended to increase accessibility while reducing vehicle travel, they require accessibility-based analysis to evaluate their benefits.

**Table 5**      **Mobility Management Strategies (VTPI, 2006)**

Improves Transport Options	Incentives for Efficiency	Land Use Management	Policy & Planning Reforms
Transit improvements	Congestion pricing	Smart growth	Commute trip reduction programs
Walking and cycling improvements	Distance-based fees	New urbanism	School and campus transport management
Rideshare programs	Employee transportation benefits	Location-efficient development	Freight transport management
Flextime/Compressed workweek	Parking cash out	Parking management	Tourist transport management
Carsharing	Parking pricing	Transit oriented development	Transit marketing
Telework	Pay-as-you-drive vehicle insurance	Car free planning	Nonmotorized encouragement
Bike/transit integration	Fuel tax increases	Traffic calming	
Guaranteed ride home			

*This table lists various types of mobility management strategies.*

Prioritization tends to be most effective if implemented as part of an integrated mobility management program that improves travel options and land use accessibility. For example, road pricing and HOV lanes may fail to improve accessibility if implemented alone, but may provide significant net benefits if implemented in conjunction with ridesharing and transit service improvements on that corridor, and transit-oriented development in destination areas. Planning should therefore evaluate mobility management packages rather than individual strategies.

When all impacts are considered, prioritization is often the most cost-effective way to improve accessibility because it increases the value provided by each unit of mobility. However, these benefits can be difficult to quantify using mobility-based evaluation, and so they tend to be undervalued by conventional transport planning.

*Implications:*

- Various prioritization strategies (often called *transportation demand management* or *mobility management*) can increase transport system efficiency by favoring higher value trips and more efficient modes. This increases the value provided by a given amount of mobility and give expenditures on transport facilities and services.
- Favoring basic mobility and accessibility tends to increase economic efficiency and social benefits.
- Prioritization strategies affect the relative accessibility of different modes and locations.
- Prioritization is often the most cost-effective way to improve accessibility and addressing transport problems, but tends to be undervalued by conventional evaluation.
- Mobility management evaluation requires accessibility-based analysis which recognizes that some travel has more value than others.

### ***The Value of Inaccessibility***

Most transport planning assumes that increased accessibility and mobility provide net benefits to society. Yet, inaccessibility provides benefits and increased mobility often imposes significant external costs. For example, many people dream of living on an isolated rural community or island for the sake of quiet, privacy and community cohesion. Expanded transport facilities and increased vehicle traffic impose significant external costs (such as increased infrastructure costs, congestion, accident risk, neighborhood disruptions, energy consumption and pollution emissions) which may offset much of the benefits of increased mobility. Comprehensive analysis of accessibility and mobility should therefore account for these external costs, and not assume that increased accessibility and mobility are necessarily beneficial.

Many people want to live in a rural community but work and shop in a city. As a result, there is often significant demand for urban fringe accessibility improvements. Yet, this can spoil the amenities that urban fringe residents desire. Households that moved 10-miles from the city to enjoy rural life soon find their area is spoiled by development, so they must move further away, making willingness to drive a limiting factor. This trend continually expands the urban fringe and increases transport costs, exacerbating urban sprawl and transportation problems such as congestion, accidents and pollution.

#### *Implications:*

- Current planning generally fails to consider the disamenities associated with increased accessibility and the external costs of increased mobility, and so tends to overstate the benefits of increased access and mobility.
- To the degree that automobile travel is underpriced, current levels of motor vehicle travel will be economically excessive, and accommodating this demand is likely to be economically harmful.
- Communities may be better off limiting accessibility and mobility, particularly where isolation, quiet, independence and community cohesion are valued, and vehicle travel may impose significant externalities.

**Summary of Factors Affecting Accessibility**

The table below lists factors that affect accessibility and the degree to which they are considered in current transport planning. Some of these factors tend to be overlooked or undervalued, particularly nonmotorized travel demand, alternative mode service quality, user information, integration, affordability, prioritization and the value of inaccessibility.

**Table 6 Summary of Factors Affecting Accessibility**

Name	Description	Current Consideration
Transport Demand	The amount of mobility and access that people and businesses would choose under various conditions (times, prices, levels of service, etc).	Motorized travel demand is well studied, but nonmotorized demand is not. Travel demand is often considered exogenous rather than affected by planning decisions.
Mobility	The distance and speed of travel, including <i>personal mobility</i> (measured as person-miles) and <i>vehicle mobility</i> (measured as vehicle-miles).	Conventional transport planning primarily evaluates mobility, particularly vehicle mobility.
Transportation Options	The quantity and quality of access options, including walking, cycling, ridesharing, transit, taxi, delivery services, and telecommunications. Qualitative factors include availability, speed, frequency, convenience, comfort, safety, price and prestige.	Motor vehicle options and quality are usually considered, using indicators such as roadway level-of-service, but other modes lack such indicators and some important service quality factors are often overlooked.
User information	The quality (convenience and reliability) of information available to users on their mobility and accessibility options.	Frequently considered when dealing with a particular mode or location, but often not comprehensive.
Integration	The degree of integration among transport system links and modes, including terminals and parking facilities.	Automobile transport is generally well integrated, but connections between other modes are often poorly evaluated.
Affordability	The cost to users of transport and location options relative to incomes.	Automobile operating costs and transit fares are usually considered.
Mobility Substitutes	The quality of telecommunications and delivery services that substitute for physical travel.	Not usually considered in transport planning.
Land Use Factors	Degree that factors such as land use density and mix affect accessibility.	Considered in land use planning, but less in transport planning.
Transport Network Connectivity	The density of connections between roads and paths, and therefore the directness by which people can travel between destinations.	Conventional planning seldom considers the effects of roadway connectivity on accessibility.
Roadway Design and Management	How road design and management practices affect vehicle traffic, mobility and accessibility.	Some factors are generally considered, but others are not.
Prioritization	Various strategies that increase transport system efficiency.	Often overlooked or undervalued in conventional planning.
Inaccessibility	The value of inaccessibility and isolated.	Not generally considered in transport planning.

*This table indicates factors that affect accessibility and whether they are currently considered in planning.*



## Perspectives

Accessibility can be viewed from various perspectives, such as a particular person, group, mode, location or activity. It is therefore important to specify the perspective being considered when evaluating accessibility. For example, a particular location may be very accessible to some modes and users, but not to others.

### *Individuals and Groups*

Planning should account for different people and groups’s differing accessibility needs and abilities, as indicated in Table 7. Some types of planning analysis focus on certain groups, such as commuters, customers, visitors, or people with disabilities, depending on the type of problem to be addressed.

**Table 7 Importance of Transportation Modes**

Groups	Walking	Cycling	Driving	Public Transit	Taxi	Air Travel
Adult commuters	2	1	3	2	1	1
Business travelers	2	0	3	2	3	3
College students	3	3	2	2	0	1
Tourists	3	2	3	2	2	3
Low-income people	3	2	2	3	2	0
Children	3	3	2	1	0	1
People with disabilities	3	2	1	3	2	2
Freight delivery	0	1	3	0	1	1

*Different groups tend to rely more on certain modes. Rating from 3 (most important) to 0 (unimportant).*

Certain types of planning require *basic accessibility* analysis, which focuses on people who experience the greatest degree of accessibility constraints. This requires categorizing people according to attributes such as:

- Vehicle accessibility (degree that people have a motor vehicle available for their use).
- Physical and communication ability (consideration of various types of disabilities, including ambulatory, visual, auditory, inability to read, etc.).
- Income. In general, people in the lowest income quintile can be considered poor.
- Commuting. The degree to which people must travel regularly to school or work.
- Dependencies. The degree to which people care for children or dependent adults.

A *transportation deprivation index* can be calculated which assigns points for factors that indicate people are transportation disadvantaged, as illustrated in the following table.

**Table 8 Transport Deprivation Index Example**

Factor	Rating System	Rating
Vehicle Accessibility	One point for each day of the week that the person normally cannot use an automobile.	
Physical ability	4 points for ambulatory or visual impairment; 3 for auditory impairment; 2 for communication impairment	
Poverty	3 if in the lowest quintile and 6 if in the lowest 10% income class.	
Commute Responsibility	One point for each day of the week that the person typically commutes outside their home.	
Dependencies	3 points for each child or disabled adult who normally depends on that person for physical caregiving.	
<i>Totals</i>	<i>10-20 = moderate disadvantage. 20+ indicates severe disadvantage.</i>	

*This table describes a rating system for identifying people who are transportation disadvantaged. It can be adjusted to reflect specific planning needs and community values.*

### **Mode**

Different modes provide different types of accessibility and have different requirements, as summarized in Table 9. For example, walking and cycling provide more local access, while driving and public transit provide more regional access.

**Table 9 Comparison of Transportation Modes** (“Transport Diversity,” VTPI, 2006)

Mode	Speed	User Cost	User Requirements	Facilities
Walking	Low	Low	Physical ability	Walkways
Cycling	Medium	Low	Physical ability	Paths/roads
Public Transit	Medium	Medium	Minimal	Roads/Rails
Intercity Bus and Rail	High	Medium	Minimal	Roads/Rails
Commercial Air Service	Very High	High	Minimal	Airports
Taxi	High	High	Minimal	Roadways
Private Automobile	High	High	License	Roadways
Ridesharing	Moderate	Low	Minimal	Roadways
Carsharing	High	High	License	Roadways
Telecommunications	NA	Varies	Equipment	Equipment
Delivery Services	NA	Medium	Availability	Roadways

*Different modes have different accessibility profiles.*

### **Location**

A particular location’s accessibility can be evaluated based on distances and mobility options to common destinations. For example, some areas are automobile-oriented, located on major highways with abundant parking, poor pedestrian and transit access, and few nearby activities. Other areas are transit-oriented, with high quality transit service, comfortable stations, good walking conditions (since most transit trips include walking links), and nearby activities serving transit users (such as employment centers, retail, and public services, particularly those that serve people with lower incomes and disabilities).

***Activity***

Certain types of activities involve certain types of users, travel requirements, modes or locations which affect their accessibility. For example, worksites with many lower-income employees need walking, cycling, ridesharing and public transit access; industrial and construction activities need freight vehicle access; hospitals need access for emergency vehicles and numerous shift workers.

***Summary***

Accessibility evaluation should consider various perspectives, including different people, groups, modes, locations and activities. Accessibility evaluation often requires separate analysis for specific perspectives, and accessibility improvements may be targeted at specific groups, modes, locations or activities. For example, it is often appropriate to analyze the quality of accessibility to a particular destination or activity by various groups including motorists, non-drivers, people with disabilities and delivery vehicles.

## Evaluating Accessibility

*Evaluation* refers to methods of measuring the impacts of an activity or decision, such as the costs and benefits of various transportation improvement options. The methods used for evaluation affect planning decisions (Levinson and El-Geneidy 2007; Litman 2003).

Current evaluation practices tend to measure *mobility* rather than overall *accessibility*. Traffic models are commonly used to evaluate automobile and transit service quality. They measure travel speeds, operating costs and fares. Such models only account for travel between zones, not travel within zones; many fail to account for generated traffic impacts (which overstates the congestion reduction benefits of roadway capacity expansion); few incorporate transit service quality factors other than travel speed; and they often do a poor job of predicting the impacts of mobility management strategies such as pricing reforms, HOV priority measures or improved user information.

How certain factors are measured can significantly affect analysis results. For example:

- Accessibility should generally be measured door-to-door, taking into account the travel links from origins to vehicles and from vehicles to destinations. For example, delays finding a parking space should be counted as part of travel time costs.
- Travel time costs should reflect factors such as comfort and convenience. For example, congestion and crowding increase unit costs (“Travel Time Costs,” Litman, 2006a).
- Travel distances should be based on actual network conditions, rather than as-the-crow-flies.
- Accessibility analysis should consider costs such as vehicle ownership and parking, not just vehicle operating costs.

Current transportation evaluation methods often fail to incorporate many these factors. They generally focus on impacts that are easy to measure at the expense of more difficult to measure impacts. For example, current transport models generally assign the same travel time cost value to all travel, regardless of comfort and convenience. This favors transport system improvements that increase vehicle travel speeds over improvements that increase travel comfort and convenience (such as nicer walking conditions, more pleasant transit waiting areas and reduced transit vehicle crowding).

The *Access to Destinations* study (El-Geneidy and Levinson 2006) uses detailed data on land use, travel behavior, and population demographics to evaluate accessibility in a particular situation. It involves the following steps:

- *Accessibility definition.* A consistent definition of accessibility is needed that can be applied to various modes.
- *Land use activities.* Destination information can be developed by activity type (e.g., employment, housing, retail, education, and recreation).
- *Accessibility by mode to destinations.* This information can be used to measure accessibility by mode for specific activities and geographic locations in order to compare accessibility for different groups (such as motorists versus non-drivers, and residents of specific neighborhoods), and track how this changes over time or in response to planning decisions.

Cheng and Agrawal (2010) developed a time-based method to visualize and analyze transit service coverage—a computer application called the *Time-Based Transit Service Area Tool* (TTSAT) which incorporates total trip travel time into the transit service area maps it generates. To make these travel-time estimates realistic, TTSAT integrates all segments of a complete, door-to-door transit trip into the trip time calculations. TTSAT’s mapping and analysis capabilities offer numerous potential applications for planners, developers, and members of the public working to create transit-accessible communities.

Walkability deserves particular attention in accessibility analysis because it is an important mode itself, and supports other modes. For example, improved walking conditions increases the range of parking facilities that serve a destination, which improves automobile access, and most transit trips include walking links, so walkability improvements can improve transit accessibility. When measured based on distance, as is common in conventional transport planning, nonmotorized modes represent a tiny portion of total travel, suggesting that it is unimportant, but when measured based on time, as people generally experience travel, nonmotorized modes represent a significant portion of travel and so are recognized as relatively important, as illustrated in Figure 12. This is one facet of shifting from mobility-based to accessibility-based evaluation.

**Figure 12** Portion of Travel By Various Units (DfT 2003)

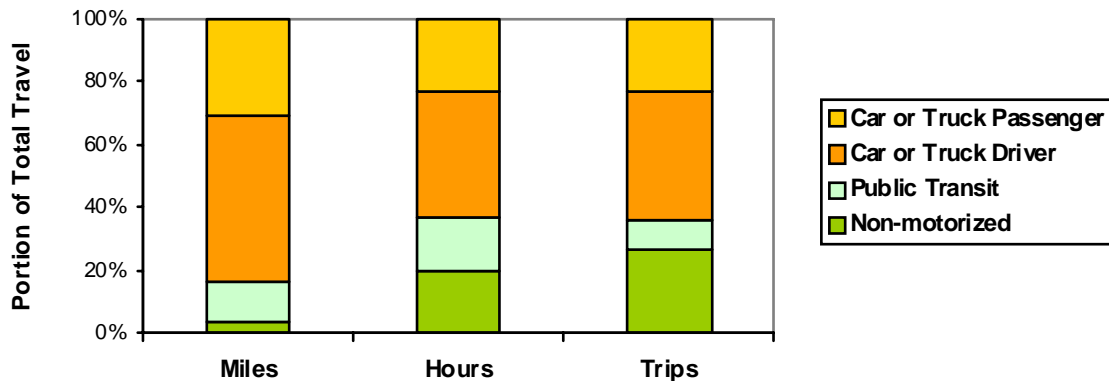

*Nonmotorized modes only represent 3-5% of travel distance, implying low importance, but 20-25% of travel time and trips, indicating greater importance.*

Accessibility can be measured based on *generalized costs* (time and money) when evaluating the users perspective, and *total costs* (including indirect and non-market costs) when evaluating society’s perspective. For example, commute accessibility can be evaluated by measuring the combined time and money that students and employees spend getting to school and work. The results can be evaluated to determine whether those costs are excessive, how commute accessibility varies for different demographic groups and geographic locations, and how various transportation system changes affect accessibility.

For evaluation and planning it is often useful to identify specific accessibility constraints. For example, for some times, locations or groups, accessibility may be constrained by traffic congestion, financial costs, or walking ability.

No single evaluation method can evaluate all accessibility factors; various overlapping methods reflect different impacts, scales and perspectives. A particular planning decision may require use of multiple methods. For example, pedestrian accessibility evaluation requires local scale analysis that takes into account factors such as sidewalk and crosswalk quality, roadway traffic speed and volume, and inclines, plus surveys of users and potential users to identify perceived barriers and problems. Walking is particularly important for certain demographic groups (children, low income households, tourists) and in geographic locations (downtowns, to schools and parks), so walkability analysis is important for evaluating accessibility for these groups and areas.

To the degree that current planning practices favor mobility over accessibility, they result in sub-optimal investment in alternative modes (Martens 2006). More comprehensive evaluation considers more impacts and options. Table 10 indicates reforms needed for more comprehensive and objective evaluation.

**Table 10 Conventional Versus Comprehensive Evaluation (Litman 2007)**

	Description	Conventional	Comprehensive
Generated Traffic & Induced Travel	Whether planning accounts for generated traffic and induced travel impacts.	Ignore or applies limited analysis	Comprehensive analysis
Downstream Congestion	Additional congestion on surface streets that results from increased highway capacity.	Generally ignored	Considered
Vehicle Costs	Which vehicle costs are considered.	Operating costs only	Ownership and operating costs
Parking Costs	Parking costs	Only user fees	All parking costs
Construction Impacts	Whether construction period congestion delays are considered.	Ignores	Includes
Nonmotorized Travel Impacts	Whether walking and cycling convenience, safety, comfort and cost are considered.	Limited analysis	Comprehensive analysis
Transit Service Quality	Whether transit comfort and convenience are fully valued.	Undervalues transit quality	Values all transit quality factors.
Transportation Diversity	Whether all the benefits of improving mobility options (particularly for non-drivers) are considered.	Limited analysis	Comprehensive analysis
Environmental Impacts	Range and detail of environmental impacts considered in analysis.	Limited analysis	Comprehensive analysis
Community Livability	Impacts on community livability, including neighborhood walkability and affordability.	Limited analysis	Comprehensive analysis
Equity Impacts	Whether impacts on community equity objectives are considered.	Limited analysis	Comprehensive analysis
Land Use Impacts	Whether impacts on land use development objectives (e.g., smart growth) are considered.	Limited analysis	Comprehensive analysis
Safety and Health	Consideration of safety and health impacts.	Crash rates	All health impacts

*Conventional evaluation tends to overlook many of the costs of increased automobile traffic and many of the benefits of alternative modes and mobility management.*

Newer models incorporate multi-modal LOS factors to better evaluate walking, cycling, public transit and parking conditions (FDOT 2007). Table 11 describes various ways of improving current models to make their analysis more accurate and comprehensive.

**Table 11**      **Transport Model Improvements** (“Model Improvements,” VTPI 2006)

Factor	Problems With Current Models	Appropriate Corrections
Accessibility	Most transportation models primarily evaluate <i>mobility</i> (movement), and fail to reflect <i>accessibility</i> (people’s ability to obtain desired goods and activities).	Develop multi-modal models which indicate the quality of nonmotorized and transit travel, and integrated transportation/land use models which indicate accessibility.
Modes considered	Most current models only consider automobile and public transit.	Expand models to evaluate other modes, including walking and cycling.
Travel data	Travel surveys often undercount short trips, non-motorized travel, off-peak travel, etc.	Improve travel surveys to provide more comprehensive information on travel activity.
Consumer Impacts	Most economic evaluation models apply relatively crude analysis of consumer impacts. For example, they assume that shifts from driving to slower modes increase costs.	Use consumer surplus analysis to measure impacts from a users’ perspective. For example, recognize that shift to slower modes in response to positive incentives provide overall benefits.
Travel time	Most models apply the same travel time value to all travel, regardless of conditions.	Vary travel time cost values to reflect travel conditions, such as discomfort and delay.
Nonmotorized travel	Most travel models do not accurately account for nonmotorized travel and so undervalue nonmotorized improvements.	Modify existing models or develop special models for evaluating nonmotorized transportation improvements.
Impacts Considered	Current models only measure a few impacts (travel time and vehicle operating costs).	More comprehensive impact analysis, including crashes, emissions, pedestrian delay, etc.
Transit elasticities	Transit elasticity values are largely based on short- and medium-run studies, and so understate long-term impacts.	Use more appropriate values for evaluating long-term impacts of transit fares and service quality.
Self-fulfilling prophecies	Traffic projections are often reported as unavoidable, which must be accommodated, resulting in self-fulfilling prophecies of increased capacity, traffic and sprawl.	Report travel demand as a variable (“traffic will grow 20% if current policies continue, 10% with \$1 daily fees, and 0% with \$2 daily fee.”) rather than a fixed value (“traffic will grow 20%”).
Generated traffic and induced travel	Traffic models fail to account for the tendency of roadway expansion to generate additional peak-period traffic, and the additional costs from induced travel.	Incorporate various types of feedback into the traffic model. Develop more comprehensive economic analysis models which account for the economic impacts of induced travel.
Construction impacts	Economic models often fail to account for the traffic congestion costs during construction periods.	Take congestion delays into account when evaluating projects and comparing capacity expansion with TDM solutions.
Transportation diversity	Models often underestimate the benefits of improved travel options, particularly for disadvantaged people.	Recognize the various benefits that result from improving accessibility options.
Impacts on land use	Models often fail to identify how transport decisions will affect land use patterns, how this affect accessibility and strategic planning objectives.	Develop integrated transportation and land use planning models which predict how transport decisions affect land use patterns and how land use decisions affect accessibility.

*This table summarizes ways of improving computer models used in transportation planning.*

*Accessibility-based* evaluation models are available that take into account both mobility and land use factors (Kockelman, 1996; Harris, 2001; Braun, et al, 2005; Dong, et al, 2006; El-Geneidy and Levinson, 2006). These use geographic information systems (GIS) to measure the travel distance between various activities, such as average distances between homes and services, or the number of jobs within a half-hour travel distance of residents. Some also account for transport factors, such as area walkability and transit service frequency. However, even these models generally overlook some factors affecting overall accessibility, such as transit service comfort, user information availability, and perceived pedestrian security. Additional analysis may therefore be required to account for these factors.

Special analysis can evaluate the quality of accessibility for specific groups and locations. For example, evaluation of accessibility by elementary students should include analysis of the convenience, comfort, safety, affordability and speed of walking, cycling, automobile and school bus service. Similarly, evaluating accessibility of a commercial district should include analysis of the quality of walking, cycling, automobile, public transit, taxi service and parking conditions.

Martens (2006) argues that current transport evaluation practices are economically inefficient and regressive because they exaggerate the benefits of automobile-oriented improvements and undervalue improvements to alternative modes, which skews planning decisions to favor the mobility-rich (people who currently drive high mileage) to the detriment of the mobility-poor (people who currently drive low mileage and rely on alternative modes). To correct these problems he recommends the following changes to transportation modeling and economic evaluation techniques:

- Evaluate transport improvements primarily in terms of *accessibility* rather than *mobility*. For example, improvements should be rated based on the number of public services and jobs accessible to people, taking into account their ability (i.e., ability to walk and drive), travel time and financial budgets, not simply travel time savings to vehicle travelers.
- Assign value to accessibility gains inversely related to people's current levels of accessibility, to reflect the principle of diminishing marginal benefits. Accessibility gains for the mobility-poor should be valued higher than the same increase in accessibility by the mobility-rich.

Overall accessibility can be evaluated with regard to time and money budgets. People typically devote 60-90 minutes a day and 15-20% of their household budgets to transport, and are willing to spend 5-10 minutes traveling for errands such as shopping and taking children to school. If such services are sufficiently accessible for pedestrians, some people will choose to walk. If not, most people who can will drive. Similarly, thirty minutes and two to four dollars in expenses represents the maximum one-way commute budget. Transport systems that force people to exceed these time and money budgets tend to create a burden, particularly on lower-income households.



Planners can therefore evaluate:

- The quality of accessibility by different modes and in specific areas.
- The quality of accessibility by various groups and how they compare, with particular attention to the relative quality of accessibility by disadvantaged groups.
- Possible strategies for improving accessibility, including increased user comfort, convenience and affordability, not just travel speed.
- Possible strategies for improving alternative modes and reducing automobile travel.
- Which groups bear excessive time or financial costs for basic mobility.

### **Automobiles and Cities**

Automobiles are complex systems that provide mobility. By increasing travel speeds, and therefore the distance that can be traveled in a given time period, automobiles increase the goods, services and activities accessible from a particular location.

Cities are complex systems that provide accessibility. By reducing the distances between destinations and improving transport options (better walking conditions and public transit services) cities also increase the goods, services and activities accessible from a particular location.

These two methods of improving accessibility often conflict. Transportation planning decisions intended to enhance automobile travel (wider roads, increased traffic speeds, larger parking facilities, highway-oriented development) often degrade urban conditions and travel services.

Conventional transport planning recognizes the benefits of mobility but often overlooks the benefits of urban accessibility. For much of the last century transportation planning decisions have favored mobility over urban accessibility. A more complex framework for evaluating accessibility allows decision-makers to better understand how specific policies and planning decisions will affect overall accessibility.

## **Optimal Accessibility and Mobility**

It is interesting to consider the levels of accessibility and mobility that are overall optimal, and how this is affected by the evaluation methods used. Transportation planning often assumes that any increase in mobility is beneficial and desirable, but there are, of course, various economic, social and environmental costs.

According to economic theory, the optimal levels of accessibility and mobility are the amount that consumers would choose in an optimal market, in which they have an appropriate range of travel and location options, and prices reflect costs (users bear directly all costs resulting from their transport activities). Beyond this optimum, increased mobility is economically excessive and harmful to society. Litman (2007) examines various reforms that would make transport and land use markets more efficient. These include, for example, efficient road and parking pricing, neutral planning and funding, and accessibility-based land use planning practices. The study concluded that in a more optimal market, consumers would choose to drive significantly less, rely more on alternative modes, and be better off overall as a result.

For example, charging motorists directly when they use parking facilities typically reduces vehicle travel by 10-30%, and distance-based vehicle insurance and registration fees reduce driving about 10%. Least-cost planning, which funds alternative modes and mobility management programs when they are more cost effective than facility expansion often reduces driving by 10-30%. Land use policy reforms, which correct existing market distortions that favor lower-density development patterns also tend to reduce automobile travel and encourage use of alternative modes.

In more optimal markets people would probably achieve about the same amount of accessibility, but would rely more on non-automobile strategies, including more walking, cycling, ridesharing, public transit and telecommunications, and accessible locations. For example, these reforms would give commuters more incentive to use alternative modes, families more incentive to choose homes within reasonable walking distance of schools, and businesses more incentive to choose locations served by quality public transit.

More comprehensive analysis, which takes into account more transportation impacts and options, tends to justify more support for alternative modes, constraints on driving, and accessible land use patterns. For example, considering costs such as parking subsidies and pollution emissions tends to justify more investments in alternative modes, and considering mobility management strategies and land use accessibility improvements tends to justify shifting more resources away from road and parking construction.

Although many communities are implementing some of these reforms, no communities have implemented all market based reforms. This may justify the implementation of other incentives, such as subsidies for alternative modes and restrictions on vehicle travel, on second-best grounds, and to help achieve strategic planning objectives, such as increasing land use accessibility and reducing sprawl. It is, however, difficult to determine to what degree such interventions are justified.

## Evaluating Automobile Dependency

*Automobile dependency* (also called *automobile orientation*) refers to transportation systems and land use patterns that favor automobile access and provide relatively inferior alternatives (“Automobile Dependency,” VTPI, 2006). In this case, *automobile* includes cars, vans, light trucks, SUVs and motorcycles. Its opposite is a *balanced* or *multi-modal* transportation system, meaning that consumers have relatively diverse accessibility options, although automobile travel may still be a major or even dominant mode.

Automobile dependency determines how accessibility differs between drivers and non-drivers, and therefore non-drivers’ relative disadvantage. This affects both equity (since one group is relatively worse off than others) and efficiency (since non-drivers are unable to access education and jobs). This indicates that automobile dependency is both unfair and inefficient, or described more positively, increasing transport system diversity provides both efficiency and equity benefits (Litman, 2001). Automobile dependency can be evaluated from various scales and perspectives. For example, a walkable, mixed-use neighborhood may be multi-modal at a local scale but automobile dependent at a regional scale due to poor transit service. Automobile dependency can be evaluated based on:

- Per capita annual vehicle travel.
- Mode split (portion of total travel by various modes). In general, automobile mode split over 90% indicates a high degree of automobile dependency, and less than 75% indicates a fairly multi-modal community, where non-drivers are not significantly disadvantaged.
- Mode split by discretionary travelers (use of alternative modes by people who could drive), which indicates whether alternative modes provide high service quality.
- Land use accessibility (the amount of mobility needed to reach a typical set of destinations). Ewing, Pendall and Chen (2002) developed an index that quantifies the degree of sprawl in a particular area.
- The relative difference in generalized travel costs (combined financial costs and monetized travel time) between drivers and non-drivers to reach a typical set of destinations.
- Quantity and quality of alternative modes available. This can be quantified using multi-modal level-of-service rating (FDOT 2007).
- Specific indicators, such as the portion of children who walk or bicycle to school.

Although inadequate mobility can constrain people’s ability to participate in desired activities, the increase in people’s ability to travel does not necessarily result in more participation. Just because people can access activities does not necessarily mean that they take advantage of the opportunities. For example, Farber and Páez (2009) found that automobile reliance increases social activity by people who are less mobile (home-makers and unemployed people), but decreases social activity in more mobile subgroups (full time workers). Automobile reliance is found to have a strong negative impact on the probability of visiting friends and participating in out-of-home sports and cultural events, but a positive effect on in-home and potentially asocial amusements such as television viewing.

Some people assume that automobile dependency inevitably increases with wealth, but there is evidence that many affluent people prefer transport diversity and will use alternative modes if of suitable quality. For example, many prestigious residential areas are walkable, mixed-use neighborhoods; many successful professionals prefer alternative commute modes; and many economically successful cities have declining automobile mode split (“Success Stories,” VTPI 2006). Although per capita vehicle ownership and use tend to rise as incomes increase from poverty to middle levels, the ultimate degree of automobile dependency is determined by policy and planning decisions. If decision-makers consider multi-modalism desirable they will support diversity. This indicates, as the previous section concluded, that a multi-modal transport system is overall optimal.

## Strategies for Improving Accessibility

*This section describes various ways to improve accessibility. For more information see VTPI (2006)*

Table 12 uses the list of factors that affect accessibility from Table 5 to help identify possible ways of improving accessibility. Current transport planning and evaluation practices tend to focus on certain types of accessibility improvements, particularly those that increase motor vehicle travel speeds and parking convenience, which limits the scope of potential solutions to transport problems.

**Table 12 Potential Accessibility Improvement Strategies (VTPI 2006)**

Factors	Improvement Strategies
Access and Mobility Demand	Use research to better understand people’s accessibility and mobility needs, preferences and abilities, and use social marketing strategies to develop better options that respond to these demand, and to encourage consumers to choose more efficient and equitable options.
Basic Access and Mobility	Prioritize transportation improvements and activities to favor access to goods, services and activities considered most important to society.
Mobility	Improve traffic speed and capacity, such as improving and expanding roadways.
Transportation Options	Improve the convenience, comfort, safety, reliability, affordability and speed of transport options, including walking, cycling, automobile, rideshare, taxi, carshare and public transit.
User Information	Improve the quantity and quality of user information regarding travel and location options, including signs, maps, brochures, websites and telephone services. Special attention can be given to providing convenient information on alternative modes and efficient locations.
Integration	Improve connections between different modes and destinations, such as more integrated information, fares, walkability, baggage transfers, automobile and bicycle parking.
Affordability	Improve the quantity and quality of affordable modes (walking, cycling, ridesharing, public transit, taxi and telework), and improve housing affordability in accessible locations.
Mobility Substitutes	Improve the quantity and quality of telecommunications and delivery services that substitute for physical travel.
Land Use Factors	Improve land use accessibility by increasing density and mix, in order to create activity centers and urban villages that contain the appropriate combination of housing, jobs and services within convenient walking and cycling distance.
Transport Network Connectivity	Improve road and path connectivity to allow more direct travel between destinations, including special shortcuts for non-motorized travel where appropriate.
Roadway Design and Management	Improve roadways to increase traffic flow (for example, by reducing the number of driveways), to favor higher occupant vehicles, and to improve walking and cycling conditions.
Prioritization	Use mobility and parking management strategies to favor higher value trips and more resource-efficient vehicles, and to encourage more accessible land use development.
Improve Payment Systems	Better road and parking pricing methods reduce transaction costs and increase the feasibility of implementing pricing reforms to increase overall transportation system efficiency.
Inaccessibility	Where appropriate, limit mobility and accessibility.

*This table indicates various ways to improve accessibility. Current transport planning practices tend to focus on just a few of these strategies, which limits the scope of solutions considered.*

Accessibility and mobility demand varies depending on the quality of options available. Many consumers would prefer to reduce their vehicle travel and rely more on alternative modes and more accessible locations, provided those alternatives are suitably convenient, comfortable, safe, affordable and prestigious (Levine and Frank 2006). Accessibility can be improved by developing new transport and location options that better respond to consumer needs and preferences (“Mobility Management Marketing,” VTPI 2006).

Opportunities for improving transportation system services can be identified by inviting suggestions from users, and by auditing various types of trips (for example, a suburb-to-downtown commute trip by various modes). It is useful if transportation decision makers (planners and public officials) regularly rely on alternative modes so they can experience the transportation system from a user’s perspective, in order to help identify problems and opportunities for improvement.

Automobiles provide the majority of personal mobility in most developed regions, so accessibility can be improved by increasing roadway capacity and design speeds, improving traffic management, improving parking facility capacity and convenience, and increasing vehicle safety. However, it is important to consider the negative effects that wider roads, increased vehicle traffic volumes and speeds, and more dispersed land use development patterns can have on other forms of accessibility.

Prioritization can improve accessibility for higher value trips and more efficient modes, for example, by favoring vanpools, transit and freight vehicles over lower value vehicles on congested roadways. These strategies tend to be most effective if implemented as part of an integrated program that improves travel options and land use accessibility. This is particularly important in urban areas where it is costly to expand facilities and where increased traffic imposes significant external costs.

Non-motorized modes (walking, cycling and their variants such as wheelchairs and scooters) are particularly important because they represent a major portion of total travel, and support other modes. For example, most transit trips include walking links, so improving walking conditions can improve transit accessibility. Nonmotorized improvements include improved sidewalks, crosswalks, paths, bikelanes, traffic calming and vehicle restrictions, safety education, law enforcement and encouragement programs, bicycle parking, improved security and *universal design* (facilities designed to accommodate all users, including people who rely on mobility aids such as wheelchairs and walkers. More compact and mixed land use, narrow roads, short blocks and pedestrian shortcuts tend to improve walkability.

Public transit improvements can increase mobility and accessibility in several ways. They improve mobility for non-drivers and increase transport affordability, and they can reduce traffic and parking congestion by attracting discretionary travelers (people who would otherwise drive). In addition, high quality transit often provides a catalyst for more accessible, walkable land use development patterns, which further increases mobility options and improves accessibility (“Transit Oriented Development,” VTPI 2006).

To determine the most effective accessibility improvements in a particular situation it is helpful to identify the major accessibility constraints that apply and develop appropriate responses, as illustrated in Table 13.

**Table 13 Accessibility Constraints And Solutions**

User Group	Major Accessibility Constraints	Improvement Strategy
Urban commuters	Traffic and parking congestion.	Expand roads and parking facilities, improve alternative modes (particularly grade-separated public transit), congestion pricing.
Low-income commuters	Fuel costs, parking costs and vehicle unreliability	Subsidize fuel and parking. Improve affordable transport options (walking, cycling, ridesharing, public transit). Increase housing affordability in accessible locations.
Non-drivers	Inadequate alternative modes and poor connections between these modes (such as difficulty taking a bicycle on a bus).	Improve walking and cycling conditions, rideshare and public transit services, user information, connections among modes.
Children/teenagers	Poor walking and cycling conditions, inadequate public transit services.	Improve walking and cycling conditions (particularly safety), improve public transit, provide suitable user information.
Visitors and mode shifters	Inconvenient user information.	Improve user information.
Mode shifters	Stigma (walking, cycling and public transit are considered inferior)	Marketing to increase the status of alternative modes.
People with disabilities	Unsuitable walking facilities, unsuited vehicles (automobiles, public transit and taxi), inadequate user information.	Improve pedestrian facilities and vehicles to accommodate mobility aides, improve user information.
People with physical disabilities	Constraints described above, plus financial constraints.	Low transit and taxi fares, targeted discounts for low-income disabled people, special telephone and Internet services.
Shippers	Congestion delays, inconvenient parking (particularly for urban deliveries), high fuel costs.	Congestion pricing (so higher value trips can outbid lower value trips on congested roads), better delivery vehicle parking options, development of more fuel efficient shipping services (such as rail transport).

*This table indicates the major accessibility constraints facing specific types of people or situations, and appropriate responses. This type of analysis should be adjusted to reflect specific situations.*

Accessibility-based planning tends to expand the range of impacts and options that can be considered. For example, conventional planning may assume that the main way to address traffic and parking congestion is to expand roads and parking facilities, but accessibility-based planning considers other factors, including the tendency of wider roads and larger parking lots to reduce accessibility by other modes (particularly walking and public transit), and the potential to address such problems by improving travel options and increasing land use accessibility.

## Examples

### Access to Destinations ([www.cts.umn.edu/access-study](http://www.cts.umn.edu/access-study))

*Access to Destinations* is an interdisciplinary research program by the University of Minnesota's *Center for Transportation Studies* which uses a more comprehensive approach to understanding how people use the transportation system, and how transportation and land use interact. It reflects the concept of accessibility: the ability of people to reach destinations that meet their needs. It considers multiple modes of transportation, including non-motorized transport, public transit, and automobile use. Accessibility is also concerned with land use and development patterns, and the ways in which land use influences and is affected by transportation.

The researchers refined methods for calculating auto and non-auto travel times, developed methods for describing how our regional accessibility changes, developed tools for evaluating how various transportation and land-use policies affect future accessibility and created an interactive *Metro Accessibility Matrix* Internet tool that lets users generate accessibility maps for Twin Cities (Minneapolis/St Paul) region.

### Key findings:

- In 1995 there was only one traffic analysis zone (located near the center of the metro region) from which commuters could reach more than one million jobs within 20 minutes. By 2005, there were 20 such zones. Well over half the population of the region can reach more than one million jobs within 30 minutes, and almost everyone can reach a million jobs within 45 minutes.
- These accessibility increases occurred while the center of gravity for employment was shifting—slightly—toward the south and west of the region. Accessibility got better despite the absence of a matching shift on the part of workers. The labor force tended to shift more toward zones north and south of Minneapolis. The overall ratio of jobs to workers has been improving (getting closer to 1:1) in most areas of the region.
- The region has seen small but measurable decreases in walking travel time. Making it easier and safer to walk (for example, by adding new pedestrian facilities such as the Midtown Greenway in Minneapolis) raises walking's desirability and reduces the time involved in a walking trip.
- A third of walking trips exceeded a mile, calling into question the long-standing assumption that a quarter-mile is the limit of willingness to walk on a regular basis to any destination.
- New bike networks and facilities (such as the off-street trail along Hiawatha Avenue) also had a measurable effect.
- The region's first light-rail line had a positive effect on many accessibility measures. Against the background of general accessibility increases, gains have been proportionately greater along the Hiawatha light-rail corridor and near bus lines offering high-frequency service.



## Best Practices

*Below are recommendations for best practices when evaluating transportation and accessibility.*

- Transportation should be evaluated based on *accessibility* in addition to *mobility*.
- Accessibility evaluation should consider all factors that may affect access, including people's needs and abilities, the availability and quality of various access options, land use factors, network connectivity, mobility substitutes and land use patterns.
- Transport planning should identify specific accessibility *constraints* in a particular situation (specific people, times, locations, types of travel, etc.). For example, traffic congestion may be a major constrain in some situations, while in others the constraint is inadequate user information, poor walkability, or high financial costs.
- Accessibility evaluation should give special consideration to the access needs of disadvantaged groups, including people with disabilities and low incomes. The quality of their access can be evaluated relative to average accessibility levels.
- Accessibility evaluation should account for qualitative factors such as user convenience, comfort, affordability, security and consumer preferences.
- Accessibility evaluation should account for the quality of modal integration, such as the quality of connections between modes.
- Accessibility analysis should consider various perspectives, including different individuals, groups, locations and activities.
- Analysis should consider ways that improving one form of access may reduce other forms, such as the tendency of wider roads and increased vehicle traffic to reduce pedestrian access, and the reduction in vehicle traffic speeds from traffic calming.
- Special consideration should be given to providing basic access and mobility, recognizing that certain types of access are particularly valued by society.
- Special consideration should be given to walkability because pedestrian access is important on its own, and supports other modes including ridesharing, public transit and automobile parking.
- Transportation planning should account for the benefits of inaccessibility and the external costs of vehicle traffic. Transportation policies should limit access and mobility when doing so preserves valuable social or environmental amenities.
- Transportation planning should consider a wide range of strategies for improving accessibility, including improvements to vehicle traffic, alternative modes, mobility management, mobility substitutes and more accessible land use.
- Transportation and land use planning should be integrated to optimize access. For example, land use policies should encourage clustering in areas that have good walking and cycling conditions, and good transit service.
- Transport planning should use neutral language that does not favor automobile transport over other modes, as illustrated in the box below.

**Neutral Transport Planning Language** (Lockwood 2004)

Many transport planning terms unintentionally favor motor vehicle travel over other forms of access. For example, increased road and parking capacity is often called an “improvement,” although wider roads and larger parking facilities, and the increased traffic volumes and speeds that result, tend to degrade pedestrian and cycling mobility. Calling such changes “improvements” indicates a bias in favor of one mode over others. Objective language uses neutral terms, such as “added capacity,” “additional lanes,” “modifications,” or “changes.”

The terms “traffic,” “flow,” and “trip” often refer only to motor vehicle travel. Short trips, non-motorized trips, travel by children, and non-commute trips are often undercounted or ignored in transport surveys, models, and analysis. Although automobile and transit trips often begin and end with a pedestrian or cycling link, they are often classified simply as “auto” or “transit” trips. Walking and cycling conditions are often evaluated inadequately or not at all.

The term “efficient” is frequently used to mean increased vehicle traffic speeds. This assumes that faster vehicle traffic always increases overall efficiency. This is not necessarily true. High vehicle speeds can reduce total traffic capacity, increase resource consumption, increase costs, reduce transportation options, increase crash risk, create less accessible land use patterns, and increase automobile dependency, reducing overall system efficiency.

Transportation professionals often rate the overall quality of the roadway network based on Level of Service (LOS) ratings that evaluate conditions for automobile traffic, but apply no comparable rating for other travel modes. It is important to indicate which users are considered when level of service values are reported.

<u>Biased</u>	<u>Neutral Terms</u>
Traffic	Motor vehicle traffic, pedestrian, bike traffic, etc.
Trips	Motor vehicle trips, person trips, bike trips, etc.
Improve	Change, modify, expand, widen
Enhance	Change, increase traffic speeds
Deteriorate	Change, reduce traffic speeds
Upgrade	Change, expand, widen, replace
Efficient	Faster, increased vehicle capacity
Level of service	Level of service for...

**Examples:**

**Biased:** *Level of service* at this intersection is rated “D.” The proposed *improvement* will cost \$100,000. This *upgrade* will make our transportation system more *efficient* by *enhancing* capacity, preventing *deterioration* of *traffic* conditions.

**Neutral:** *Level of service* at this intersection is rated “D” for *motorists* and “E” for *pedestrians*. A *right turn channel* would cost \$100,000. This *road widening project* will *increase motor vehicle traffic speeds and capacity* but may *reduce safety and convenience to pedestrian travel*.

## Conclusions

*Accessibility* refers to peoples' ability to reach desired goods, services, activities and destinations. The quality of accessibility has tremendous direct and indirect impacts. Improving accessibility and reducing accessibility costs can help achieve many economic, social and environmental objectives. Since accessibility is the ultimate goal of most transportation activity (excepting the small amount of travel that has no desired destination), transport planning should be based on accessibility.

Many factors affect accessibility, including people's transport needs and abilities, the quality and affordability of transport options, the degree to which various links and modes are connected, land use patterns, and the quality of mobility substitutes. This report describes these factors and how they can be evaluated. Some of these factors tend to be overlooked or undervalued in conventional transport planning, particularly nonmotorized travel demand, alternative mode service quality, user information, integration, affordability, prioritization and the value of inaccessibility.

Many current planning and evaluation practices reflect *traffic-based* (vehicle movement) or *mobility-based* (people and goods movement) analysis. These tend to favor automobile transport over other forms of accessibility, including alternative modes, mobility management, and more accessible land use. Many of these planning and evaluation biases are subtle and technical, resulting from the way that transport is defined and measured, or reflecting the formulas used to allocate transportation funding.

Optimal planning requires more comprehensive accessibility analysis. No single method can evaluate all accessibility factors: a variety of methods must be used that reflect different impacts, scales and perspectives. Our ability to evaluate accessibility is improving as we develop a better understanding of these concepts and better tools for quantifying accessibility impacts. However, accessibility-based planning techniques are still new and practitioners are still learning how to apply them to specific decisions. Effective planning therefore requires creativity and judgment to understand and evaluate the myriad factors affecting accessibility.

Improving accessibility evaluation can help reconcile conflicts inherent in current planning. Mobility-based planning favors solutions that increase motor vehicle travel, despite the diminishing benefits and increasing costs of expanding roads and parking facilities, and increasing vehicle traffic and personal mobility. A better understanding of accessibility can help identify truly optimal solutions to transport problems.

This is actually good news because it indicates that there are many more ways to improve accessibility than recognized in conventional planning. For example, many transport problems are best solved by improving the convenience and comfort of alternative modes, providing better user information, improving connections among modes, and increasing land use accessibility. However, transport planning practices will need to change for such solutions to be implemented as much as optimal.

## References And Resources For More Information

- Ted Balaker (2006), *Why Mobility Matters*, Policy Brief No. 43, Reason Foundation ([www.reason.org](http://www.reason.org)); at [www.reason.org/pb43\\_whymobilitymatters.pdf](http://www.reason.org/pb43_whymobilitymatters.pdf).
- Ted Balaker (2007), *Why Mobility Matters to Personal Life*, Policy Brief No. 62, Reason Foundation ([www.reason.org](http://www.reason.org)); at [www.reason.org/pb62.pdf](http://www.reason.org/pb62.pdf).
- Keith Bartholomew (2007), "The Machine, The Garden And The City: Towards An Access-Efficient Transportation Planning System," *The Environmental Law Reporter* ([www.elistore.org/elr.asp](http://www.elistore.org/elr.asp)), Vol. 37, No. 8, pp. 10593-10614.
- Udo Becker, Juliane Bohmer and Regine Gerike (2008), *How to Define and Measure Access and Need Satisfaction in Transport*, Papers from the ESF-Exploratory Workshop Dresden 27-28 September 2007, Dresdner Institut fur Verkehr und Umwelt ([www.divu.de](http://www.divu.de)).
- Ulrich Braun, et al (2005), *The Swiss Real Estate Market: Facts And Trends*, Credit Suisse Economic Research ([www.greaterzuricharea.ch/content/04/downloads/immo\\_cs2005en.pdf](http://www.greaterzuricharea.ch/content/04/downloads/immo_cs2005en.pdf)).
- Bryceson, Maunder, Mbara, Kibombo, Davis and Howe (2003), *Sustainable Livelihoods: Mobility and Access Needs*, Report TRL554, Transport Research Laboratory ([www.transport-links.org](http://www.transport-links.org)).
- BTS (1997), *Mobility and Access; Transportation Statistics Annual Report 1997*, Bureau of Transportation Statistics ([www.bts.gov](http://www.bts.gov)), pp. 173-192.
- BTS (2001), *Special Issue on Methodological Issues in Accessibility: Journal of Transportation and Statistics*, Vol. 4, No. 2/3, Bureau of Transportation Statistics ([www.bts.gov](http://www.bts.gov)), Sept/Dec 2001.
- Cambridge Systematics (2010), *Measuring Transportation Network Performance*, NCHRP 664, TRB ([www.trb.org](http://www.trb.org)); at [http://onlinepubs.trb.org/onlinepubs/nchrp/nchrp\\_rpt\\_664.pdf](http://onlinepubs.trb.org/onlinepubs/nchrp/nchrp_rpt_664.pdf).
- Susan Chapman and Doug Weir (2008), *Accessibility Planning Methods*, Research Report 363, New Zealand Transportation Agency ([www.landtransport.govt.nz/research/reports/363.pdf](http://www.landtransport.govt.nz/research/reports/363.pdf)).
- Chao-Lun Cheng and Asha Weinstein Agrawal (2010), "TTSAT: A New Approach to Mapping Transit Accessibility" *Journal of Public Transportation*, Vol. 13, No. 1, pp. 55-72; at [www.nctr.usf.edu/jpt/pdf/JPT13-1.pdf](http://www.nctr.usf.edu/jpt/pdf/JPT13-1.pdf).
- CLF (2007), *Regional Equity Atlas*, Coalition for a Livable Future (<http://clfuture.org>).
- Pasquale Colonna (2009), "Mobility and Transport For Our Tomorrow Roads," *Europeanroads Review 14*, Spring, pp. 44-53; at [www.vtppi.org/colonna.pdf](http://www.vtppi.org/colonna.pdf).
- CTS (2006), *About Accessibility: Access to Destinations Study*, Center for Transportation Studies, University of Minnesota ([www.cts.umn.edu](http://www.cts.umn.edu)); at [www.cts.umn.edu/access-study/about/index.html](http://www.cts.umn.edu/access-study/about/index.html).
- CTS (2010), *Measuring What Matters: Access to Destinations*, the second research summary from the *Access to Destinations Study*, Center for Transportation Studies, University of

- Minnesota ([www.cts.umn.edu](http://www.cts.umn.edu)); at [www.cts.umn.edu/Publications/ResearchReports/reportdetail.html?id=1948](http://www.cts.umn.edu/Publications/ResearchReports/reportdetail.html?id=1948).
- DfT, *2003 National Travel Survey*, UK Dept. for Transport ([www.transtat.dft.gov.uk](http://www.transtat.dft.gov.uk)), 2003.
- Xiaojing Dong, Moshe Ben-Akiva, John Bowman and Joan Walker (2006), "Moving From Trip-Based to Activity-Based Measures of Accessibility," *Transportation Research A*, Volume 40, Issue 2 ([www.elsevier.com/locate/tra](http://www.elsevier.com/locate/tra)), Feb. 2006, pp. 163-180.
- Ahmed El-Geneidy and David Levinson (2006), *Access to Destinations: Development of Accessibility Measures*, Center for Transportation Studies, University of Minnesota ([www.cts.umn.edu](http://www.cts.umn.edu)); at [www.cts.umn.edu/access-study/publications](http://www.cts.umn.edu/access-study/publications).
- David Engwicht (1993), *Reclaiming Our Cities and Towns: Better Living with Less Traffic*, New Society Publishers ([www.newsociety.com](http://www.newsociety.com)).
- Reid Ewing (1996), *Best Development Practices; Doing the Right Thing and Making Money at the Same Time*, Planners Press (Chicago; [www.planning.org](http://www.planning.org)).
- Reid Ewing, Rolf Pendall and Don Chen (2002), *Measuring Sprawl and Its Impacts*, Smart Growth America ([www.smartgrowthamerica.org](http://www.smartgrowthamerica.org)).
- Steven Farber and Antonio Páez (2009), "My Car, My Friends, And Me: A Preliminary Analysis Of Automobility And Social Activity Participation," *Journal of Transport Geography*, Vol. 17, pp. 216–225.
- FDOT (2007), *Quality/Level of Service Handbook*, Florida Department of Transportation ([www.dot.state.fl.us/Planning/systems/sm/los/default.htm](http://www.dot.state.fl.us/Planning/systems/sm/los/default.htm)).
- David J. Forkenbrock and Glen E. Weisbrod (2001), *Guidebook for Assessing the Social and Economic Effects of Transportation Projects*, NCHRP Report 456, TRB ([www.trb.org](http://www.trb.org)), 2001.
- K.T. Geurs, and J.R. Ritsema van Eck (2002), *Accessibility Measures: Review and Applications: Evaluation of Accessibility Impacts of Land-Use Transport Scenarios, and Related Social and Economic Impacts*, Report #408505 006, Rijksinstituut Voor Volksgezondheid en Milieu (National Institute for Public Health and the Environment) ([www.rivm.nl](http://www.rivm.nl)).
- David Goldberg, Jim Chapman, Lawrence Frank, Sarah Kavage and Barbara McCann (2006), *New Data for a New Era: A Summary of the SMARTRAQ Findings*, SmartTraq ([www.act-trans.ubc.ca](http://www.act-trans.ubc.ca)) and Smart Growth America ([www.smartgrowthamerica.org](http://www.smartgrowthamerica.org)); at [www.smartgrowthamerica.org/documents/SMARTRAQSummary\\_000.pdf](http://www.smartgrowthamerica.org/documents/SMARTRAQSummary_000.pdf).
- Derek Halden (2002), "Using Accessibility Measures to Integrate Land Use and Transport Policy In Edinburgh and Lothians," *Transport Policy*, Vol. 9, No. 4 ([www.elsevier.com/locate/tranpol](http://www.elsevier.com/locate/tranpol)), Oct. 2002, pp. 313-324.
- Susan Handy (1994), "Highway Blues: Nothing a Little Accessibility Can't Cure," *Access 5* ([www.uctc.net](http://www.uctc.net)), pp. 3-7; at [www.uctc.net/access/access05.pdf](http://www.uctc.net/access/access05.pdf).

Susan Handy (1993), "Regional Versus Local Accessibility; Neo-Traditional Development and its Implications for Non-Work Travel," *Built Environment*, Vol. 18, No.4, 1993, pp. 253-267; also available at University of California Transportation Center (Berkeley), #234 ([www.uctc.net](http://www.uctc.net)).

Walter G. Hansen (1959), "How Accessibility Shapes Land Use," *Journal of the American Institute of Planners*, Vol. 35, No. 2, pp. 73-76.

B. Harris (2001), "Accessibility: Concepts and Applications," *Journal of Transportation and Statistics*, Bureau of Transport Statistics ([www.bts.gov](http://www.bts.gov)), Vol. 4, pp. 15-30; at [www.bts.gov/publications/journal\\_of\\_transportation\\_and\\_statistics/volume\\_04\\_number\\_23/paper\\_02/index.html](http://www.bts.gov/publications/journal_of_transportation_and_statistics/volume_04_number_23/paper_02/index.html).

Peter Harris, Jamie Lewis and Barbara Adam (2004), "Time, Sustainable Transport and the Politics of Speed," *World Transport Policy And Practice*, Vol. 10, No. 2 ([www.eco-logica.co.uk/WTPPhome.html](http://www.eco-logica.co.uk/WTPPhome.html)), pp. 5-11.

David T. Hartgen and M. Gregory Fields (2006), *Building Roads to Reduce Traffic Congestion in America's Cities: How Much and at What Cost?*, Reason Foundation ([www.reason.org](http://www.reason.org)).

David Hensher, Peter Stopher and Philip Bullock (2003), "Service Quality - Developing a Service Quality Index in the Provision of Commercial Bus Contracts," *Transportation Research A* ([www.elsevier.com/locate/tra](http://www.elsevier.com/locate/tra)), Vol. 37, No. 6, July 2003, pp. 499-517.

Julian Hine and Margaret Grieco (2003), "Scatters And Clusters In Time And Space: Implications For Delivering Integrated And Inclusive Transport," *Transport Policy*, Vol. 10, pp. 299-306; at [http://vplno1.vkw.tu-dresden.de/oeko/Data/ESF/Paper\\_Hine\\_&\\_Grieco.pdf](http://vplno1.vkw.tu-dresden.de/oeko/Data/ESF/Paper_Hine_&_Grieco.pdf).

Michael Iacono, Kevin Krizek and Ahmed El-Geneidy (2008), *Access to Destinations: How Close is Close Enough? Estimating Accurate Distance Decay Functions for Multiple Modes and Different Purposes*, Report 2008-11, University of Minnesota ([www.cts.umn.edu](http://www.cts.umn.edu)); at [www.cts.umn.edu/Publications/ResearchReports/pdfdownload.pl?id=916](http://www.cts.umn.edu/Publications/ResearchReports/pdfdownload.pl?id=916).

ITE (2003), *Trip Generation Seventh Edition*, Institute of Transportation Engineers ([www.ite.org](http://www.ite.org)).

JRC (2011), *Location Efficiency and Housing Type—Boiling it Down to BTUs*, Jonathan Rose Companies for the U.S. Environmental Protection Agency ([www.epa.gov](http://www.epa.gov)); at [www.epa.gov/smartgrowth/pdf/location\\_efficiency\\_BTU.pdf](http://www.epa.gov/smartgrowth/pdf/location_efficiency_BTU.pdf).

Kevin Krizek, Ahmed El-Geneidy, Michael Iacono and Jessica Horning (2007), *Access to Destinations: Refining Methods for Calculating Non-Auto Travel Times*, Report No. 2, Access to Destinations Study, University of Minnesota's Center for Transportation Studies ([www.cts.umn.edu/access-study/publications](http://www.cts.umn.edu/access-study/publications)).

Kevin Krizek, Michael Iacono, Ahmed M. El-Geneidy, Chen-fu Liao, Robert Johns (2009), *Access to Destinations: Application of Accessibility Measures for Non-Auto Travel Modes*, Report No. 9, Access to Destinations Study, University of Minnesota's Center for Transportation Studies ([www.cts.umn.edu/access-study/publications](http://www.cts.umn.edu/access-study/publications)); at [www.cts.umn.edu/Publications/ResearchReports/reportdetail.html?id=1808](http://www.cts.umn.edu/Publications/ResearchReports/reportdetail.html?id=1808).

Kara Kockelman (1997), "Travel Behavior as a Function of Accessibility, Land Use Mixing, and Land Use Balance: Evidence from the San Francisco Bay Area," *Transportation Research Record 1607*, TRB ([www.trb.org](http://www.trb.org)); at [www.ce.utexas.edu/prof/kockelman](http://www.ce.utexas.edu/prof/kockelman).

Leigh, Scott & Cleary (1999), *Transit Needs & Benefits Study*, Colorado Department of Transportation ([www.dot.state.co.us](http://www.dot.state.co.us)).

Jonathan Levine and Lawrence D. Frank (2006), "Transportation And Land-Use Preferences And Residents' Neighborhood Choices: The Sufficiency Of Compact Development In The Atlanta Region," *Transportation*, Vol. 33, No. 6 ([www.springerlink.com](http://www.springerlink.com)), November 2006.

Jonathan Levine, Joe Grengs and Qing Shen (2010), *Metropolitan Accessibility and Transportation Sustainability: Comparative Indicators for Policy Reform*, National Center for Environmental Research; at [http://cfpub2.epa.gov/ncer\\_abstracts/index.cfm/fuseaction/display.abstractDetail/abstract/8441](http://cfpub2.epa.gov/ncer_abstracts/index.cfm/fuseaction/display.abstractDetail/abstract/8441).

David Levinson and Ahmed El-Geneidy (2006), *Development of Accessibility Measures*, Report No. 1 in the Series: Access to Destinations (Mn/DOT 2006-16), University of Minnesota's Center for Transportation Studies ([www.cts.umn.edu/access-study](http://www.cts.umn.edu/access-study)); part of a comprehensive research program to develop practical methods for evaluating accessibility for planning applications.

David Levinson and Ahmed El-Geneidy (2007), *Asking the Right Questions About Transportation and Land Use*, Access to Destinations Study, University of Minnesota's Center for Transportation Studies ([www.cts.umn.edu/access-study](http://www.cts.umn.edu/access-study)).

David Levinson, Kevin Krizek and David Gillen(2005), "Machine for Access," in *Access to Destinations* (ed. David Levinson and Kevin Krizek) Elsevier Publishers; at <http://nexus.umn.edu/Papers/Machine.pdf>.

Chris Lightfoot and Tom Steinberg (2006), *Travel-time Maps and their Uses*, My Society ([www.mysociety.org/2006/travel-time-maps/index.php](http://www.mysociety.org/2006/travel-time-maps/index.php)). This website describes how 'Travel-time Maps' can be used to indicate the time needed to travel from a particular origin to other areas.

Barbara Lipman (2006), *A Heavy Load: The Combined Housing and Transportation Burdens of Working Families*, Center for Housing Policy ([www.nhc.org/pdf/pub\\_heavy\\_load\\_10\\_06.pdf](http://www.nhc.org/pdf/pub_heavy_load_10_06.pdf)).

Todd Litman (2001), *You Can Get There from Here; Evaluating Transportation Diversity*, VTPI ([www.vtpi.org](http://www.vtpi.org)); at [www.vtpi.org/choice.pdf](http://www.vtpi.org/choice.pdf).

Todd Litman (2003), "Measuring Transportation: Traffic, Mobility and Accessibility," *ITE Journal* ([www.ite.org](http://www.ite.org)), Vol. 73, No. 10, October 2003, pp. 28-32; at [www.vtpi.org/measure.pdf](http://www.vtpi.org/measure.pdf).

Todd Litman (2005), *Evaluating Transportation Land Use Impacts*, VTPI ([www.vtpi.org](http://www.vtpi.org)); at [www.vtpi.org/landuse.pdf](http://www.vtpi.org/landuse.pdf).

Todd Litman (2006a), *Transportation Cost and Benefit Analysis*, VTPI ([www.vtpi.org](http://www.vtpi.org)); at [www.vtpi.org/tca](http://www.vtpi.org/tca).

Todd Litman (2006b), "Transportation Market Distortions," *Berkeley Planning Journal* ([www-dcrp.ced.berkeley.edu/bpj](http://www-dcrp.ced.berkeley.edu/bpj)), Volume 19, 2006, pp. 19-36; at [www.vtpi.org/distortions\\_BPJ.pdf](http://www.vtpi.org/distortions_BPJ.pdf).

Todd Litman (2007a), *Socially Optimal Transport Prices and Markets*, VTPI ([www.vtppi.org](http://www.vtppi.org)); at [www.vtppi.org/sotpm.pdf](http://www.vtppi.org/sotpm.pdf).

Todd Litman (2007b), *Comprehensive Transport Planning*, VTPI ([www.vtppi.org](http://www.vtppi.org)); at [www.vtppi.org/comprehensive.pdf](http://www.vtppi.org/comprehensive.pdf).

Todd Litman (2010), *Affordable-Accessible Housing In A Dynamic City: Why and How To Support Development of More Affordable Housing In Accessible Locations*, Victoria Transport Policy Institute ([www.vtppi.org](http://www.vtppi.org)); at [www.vtppi.org/aff\\_acc\\_hou.pdf](http://www.vtppi.org/aff_acc_hou.pdf).

Ian M. Lockwood (2004), *Transportation Prescription For Healthy Cities*, Glatting Jackson Transportation Urban Design Studio, for presentation and Common Ground [www.glatting.com/PDF/IML\\_RWJF\\_Paper2004.pdf](http://www.glatting.com/PDF/IML_RWJF_Paper2004.pdf).

Karel Martens (2006), "Basing Transport Planning on Principles of Social Justice," *Berkeley Planning Journal*, Volume 19 ([www-dcrp.ced.berkeley.edu/bpj](http://www-dcrp.ced.berkeley.edu/bpj)).

David Metz (2008), *The Limits to Travel: How Far Will You Go?* Earthscan ([www.earthscan.co.uk](http://www.earthscan.co.uk)).

Inshu Minocha, P. Sriraj, Paul Metaxatos and Piyushimita (Vonu) Thakuriah (2008), *Analysis of Transit Quality of Service and Employment Accessibility for the Greater Chicago Region*, Transportation Research Board 87th Annual Meeting ([www.trb.org](http://www.trb.org)).

Patricia Mokhtarian and Ilan Salomon (2001), "How Derived is the Demand for Travel? Some Conceptual and Measurement Considerations," *Transportation Research A*, Vol. 35, No. 8 ([www.elsevier.com/locate/tra](http://www.elsevier.com/locate/tra)) September 2001, pp. 695-719.

M.I. Nadri and T.P. Mamuneas (1996), *Contribution of Highway Capital to Industry and National Productivity Growth*, FHWA, USDOT.

Debbie Neimeier (1997), "Accessibility: An Evaluation Using Consumer Welfare," *Transportation*, Vol. 24, No. 4, Kluwer ([www.wkap.nl/prod/j/0049-4488](http://www.wkap.nl/prod/j/0049-4488)), Nov. pp. 377-396.

Peter Newman and Jeff Kenworthy (1999), *Sustainability and Cities: Overcoming Automobile Dependence*, Island Press ([www.islandpress.org](http://www.islandpress.org)).

Raymond Novaco and Cheryl Collier (1994), *Commuting Stress, Ridesharing, and Gender: Analyses from the 1993 State of the Commute Study in Southern California*, University of California Transportation Center (Berkeley), Working Paper #208 ([www.uctc.net](http://www.uctc.net)).

Nick Paumgarten (2007), "There and Back Again: The Soul Of The Commuter," *The New Yorker* ([www.newyorker.com](http://www.newyorker.com)), 16 April 2007, pp. 58-70.

Timothy Rood (1999), *Local Index of Transit Availability (LITA)*, LGC ([www.lgc.org](http://www.lgc.org)).

William Ross (2000), "Mobility and Accessibility: The Yin and Yang of Planning," *World Transport Policy & Practice* ([www.ecoplan.org/wtpp/wtj\\_index.htm](http://www.ecoplan.org/wtpp/wtj_index.htm)), Vol. 6, No. 2 pp. 13-19.

K. H. Schaeffer and Elliot Sclar (1980), *Access for All*, Columbia University Press (New York).



Andreas Schafer (2000), "Regularities in Travel Demand: An International Perspective," *Journal of Transportation and Statistics*, Vol. 3, No. 3 ([www.bts.gov/jts](http://www.bts.gov/jts)), December, pp. 1-32.

Karen E. Seggerman, Sara J. Hendricks and E. Spencer Fleury (2005), *Incorporating TDM into the Land Development Process*, National Center for Transportation Research, Center for Urban Transportation Research ([www.nctr.usf.edu/pdf/576-11.pdf](http://www.nctr.usf.edu/pdf/576-11.pdf)).

Sam Staley and Adrian Moore (2008), *Mobility First: A New Vision for Transportation in a Globally Competitive Twenty-first Century*, Rowman & Littlefield, Reason Foundation ([www.reason.org/road](http://www.reason.org/road)).

*Transport Geography on the Web* ([www.people.hofstra.edu/geotrans](http://www.people.hofstra.edu/geotrans)) is an Internet resource to promote access to transport geography information.

*Toolbox for Regional Policy Analysis Website* ([www.fhwa.dot.gov/planning/toolbox/index.htm](http://www.fhwa.dot.gov/planning/toolbox/index.htm)) by the US Federal Highway Administration, describes analytical methods for evaluating regional economic, social and environmental impacts of various transportation and land use policies.

Vermeulen, et al (2004), *The Price of Transport: Overview of the Social Costs of Transport*, CE Delft ([www.ce.nl](http://www.ce.nl)).

VTPI (2006), *Online TDM Encyclopedia*, Victoria Transport Policy Institute ([www.vtpi.org/tdm](http://www.vtpi.org/tdm)).

Ming Zhang (2005), *Intercity Variations In The Relationship Between Urban Form And Automobile Dependence*, TRB Annual Meeting ([www.trb.org](http://www.trb.org)).

## **Acknowledgements**

Thanks to Sumit Adhikari, William Ross and John Ernst who contributed to this paper.

[www.vtpi.org/access.pdf](http://www.vtpi.org/access.pdf)